

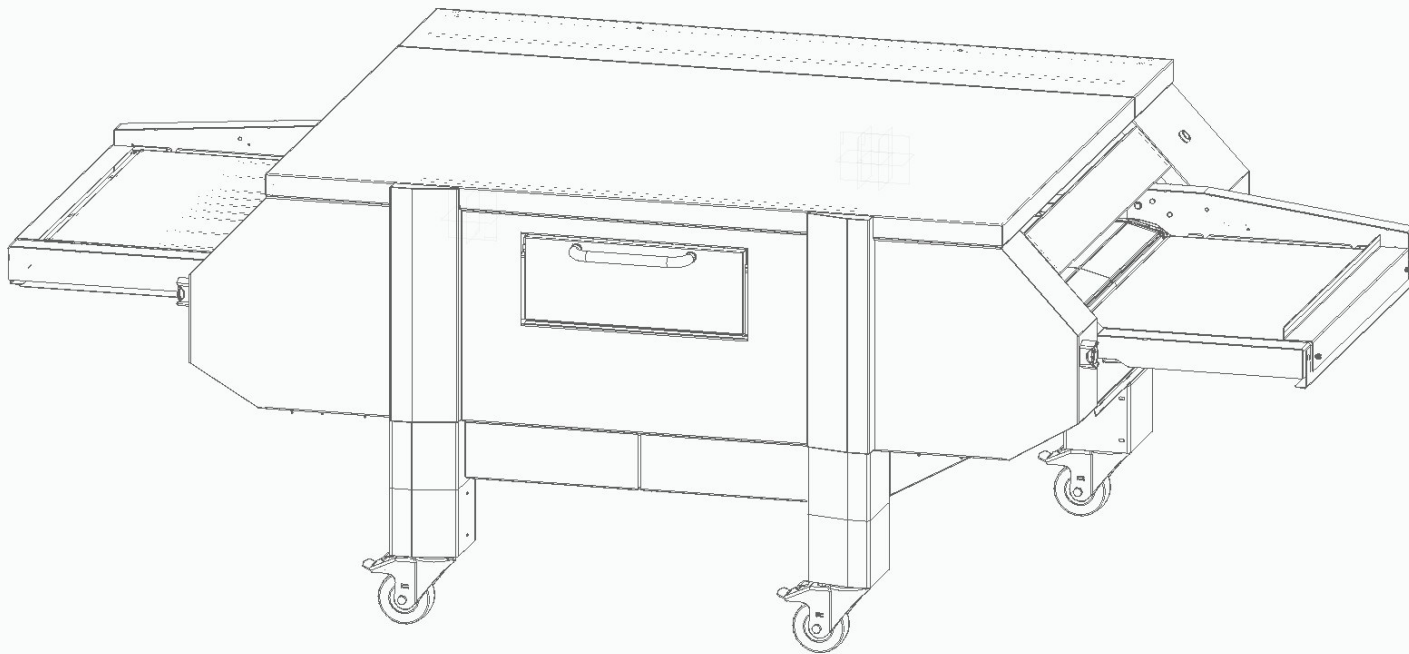

HOT ROCKS

ROCKING EVERYDAY LIFE.



# Hot Rocks Oven Parts Manual

HR-70-22, HR-70-33, HR-93-33

Gen 3

For serial number XXXXX012021 & up



A



B

#	Part #	Description	Model
A	TO0000610	6 MONTHS MAINTENANCE KIT	ALL
B	TO0000611	YEARLY MAINTENANCE KIT	ALL

Description

MAINTENANCE KIT



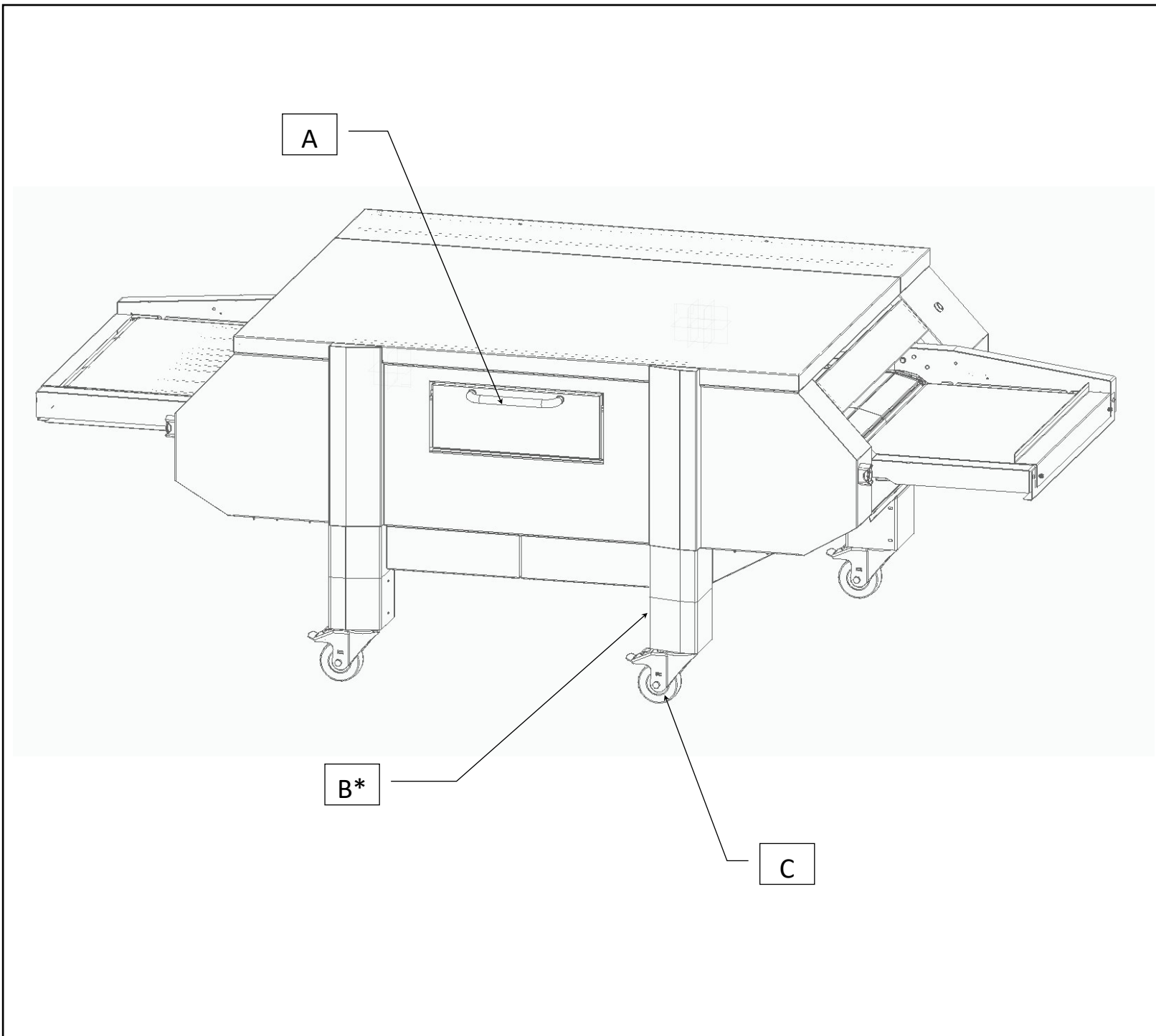

#	Part #	Description	Model
A	HR11-0087-A	DOOR WITH BRACKET	ALL
B*	HOTROCKS-LEGS-SINGLE	SINGLE STACK LEG KIT	ALL
B*	HOTROCKS-LEGS-DOUBLE	DOUBLE STACK LEG KIT	ALL
B*	HOTROCKS-LEGS-TRIPLE	TRIPLE STACK LEG KIT	ALL
C	CALL FACTORY	CASTERS	ALL

Description  
**BASE AND DOOR**



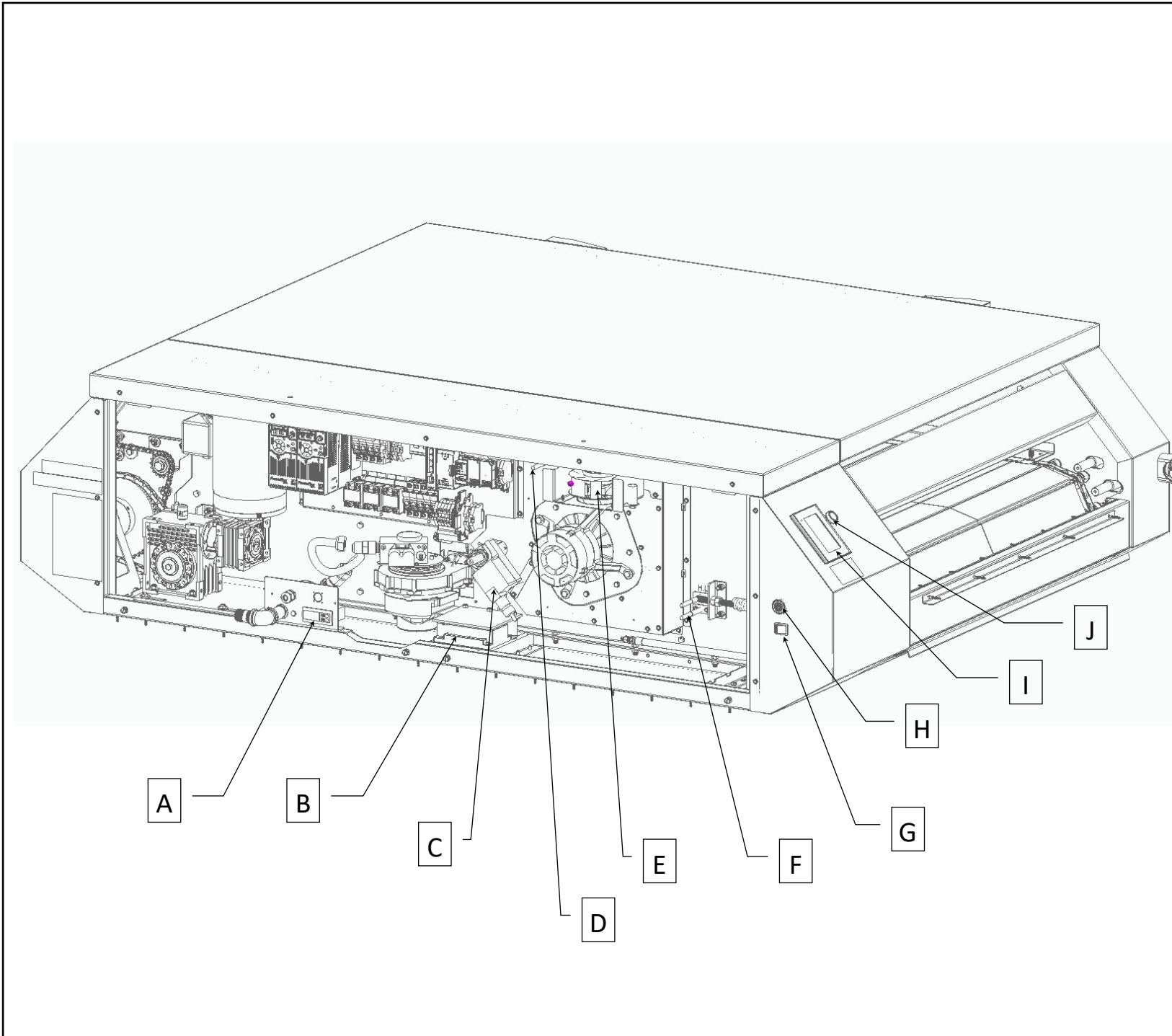

#	Part #	Description	Model
A	HR11-0049-A	HIGH LIMIT TEMPERATURE CONTROLLER	ALL
B	HR11-0067-A	IGNITION CONTROL	ALL
C	HR11-0057-A	DAMPER ACTUATOR	ALL
D	HR11-0077-A	THERMOCOUPLE 12 INCH LEAD	ALL
E	HR11-0059-A	AXIAL COOLING FAN	ALL
F	HR11-0076-A	THERMOCOUPLE 60 INCH LEAD	ALL
G	EL01-0114	ROCKER SWITCH ON/OFF	ALL
H	EL02-0094	BUZZER	ALL
I	HR11-0056-A	HMI INTERFACE	ALL
J	026-1414	REVERSE BUTTON	ALL

Description

REAR SECTION—1 of 2



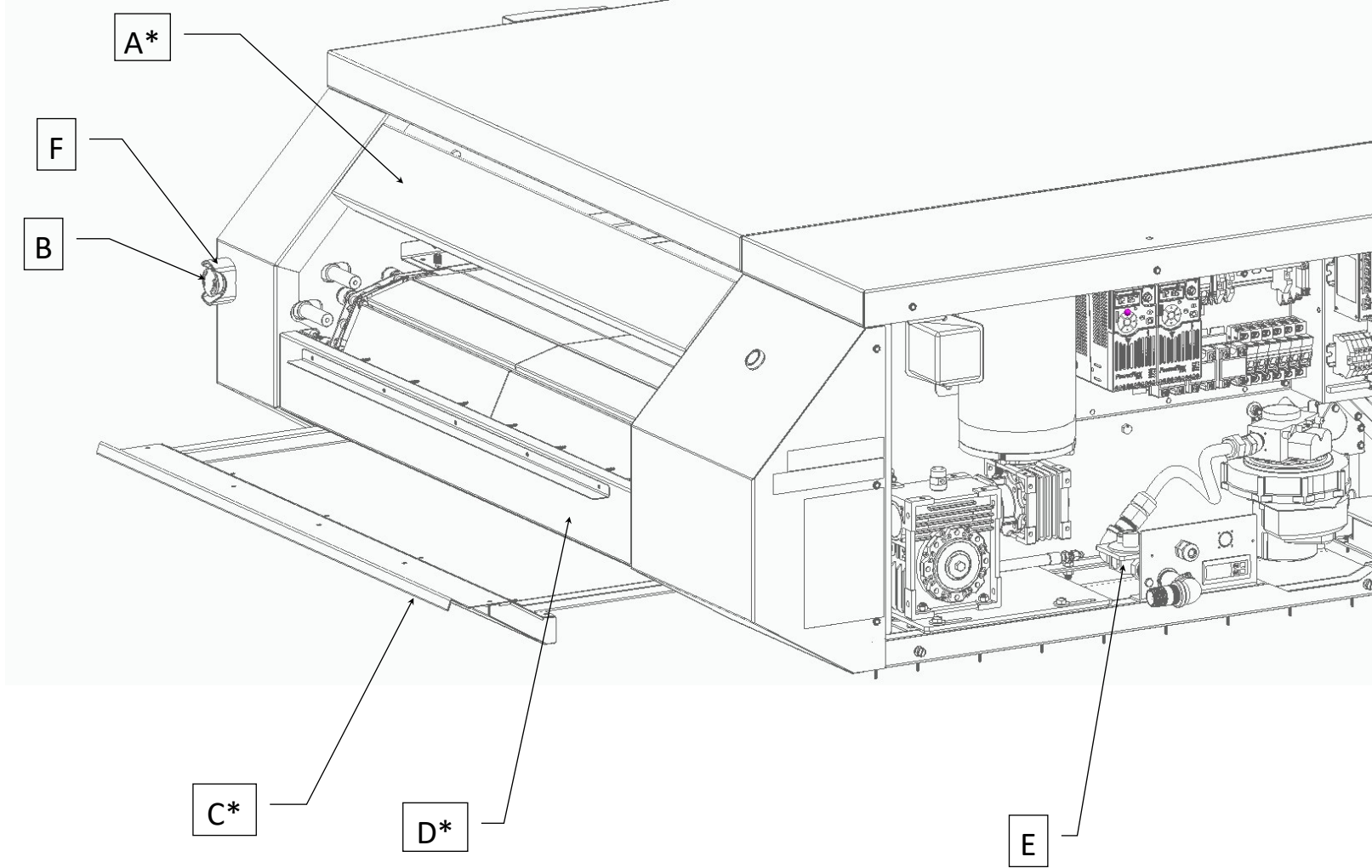

#	Part #	Description	Model
A*	HR05-0093-C	HOOD CONVEYOR	HR-XX-33
A*	HR05-0160-C	HOOD CONVEYOR	HR-XX-22
B	HR11-0027-A	EMERGENCY STOP BUTTON	ALL
C*	HR04-0140-C	CRUMB TRAY	HR-70-22
C*	HR04-0064-B	CRUMB TRAY	HR-70-33
C*	HR04-0152-B	CRUMB TRAY	HR-93-33
D*	HR05-0100-B	CONVEYOR BOTTOM HOOD	HR-XX-33
D*	HR05-0156-B	CONVEYOR BOTTOM HOOD	HR-XX-22
E	HR11-0081-A	GAS PRESSURE REGULATOR W/HOSE	ALL
F	EL01-0123	EMERGENCY STOP BUTTON PROTECTION	ALL

\* MODEL SPECIFIC

Description

REAR SECTION—2 of 2





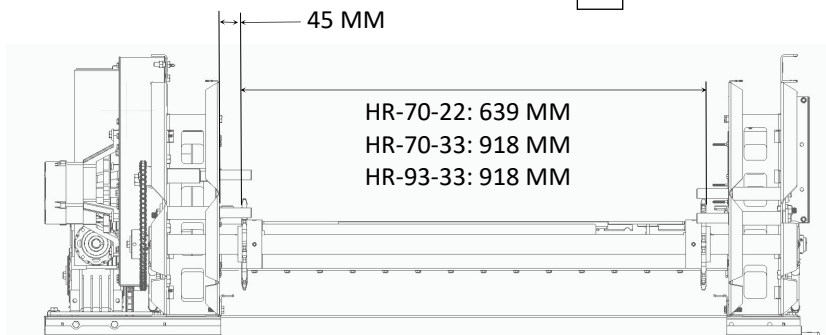
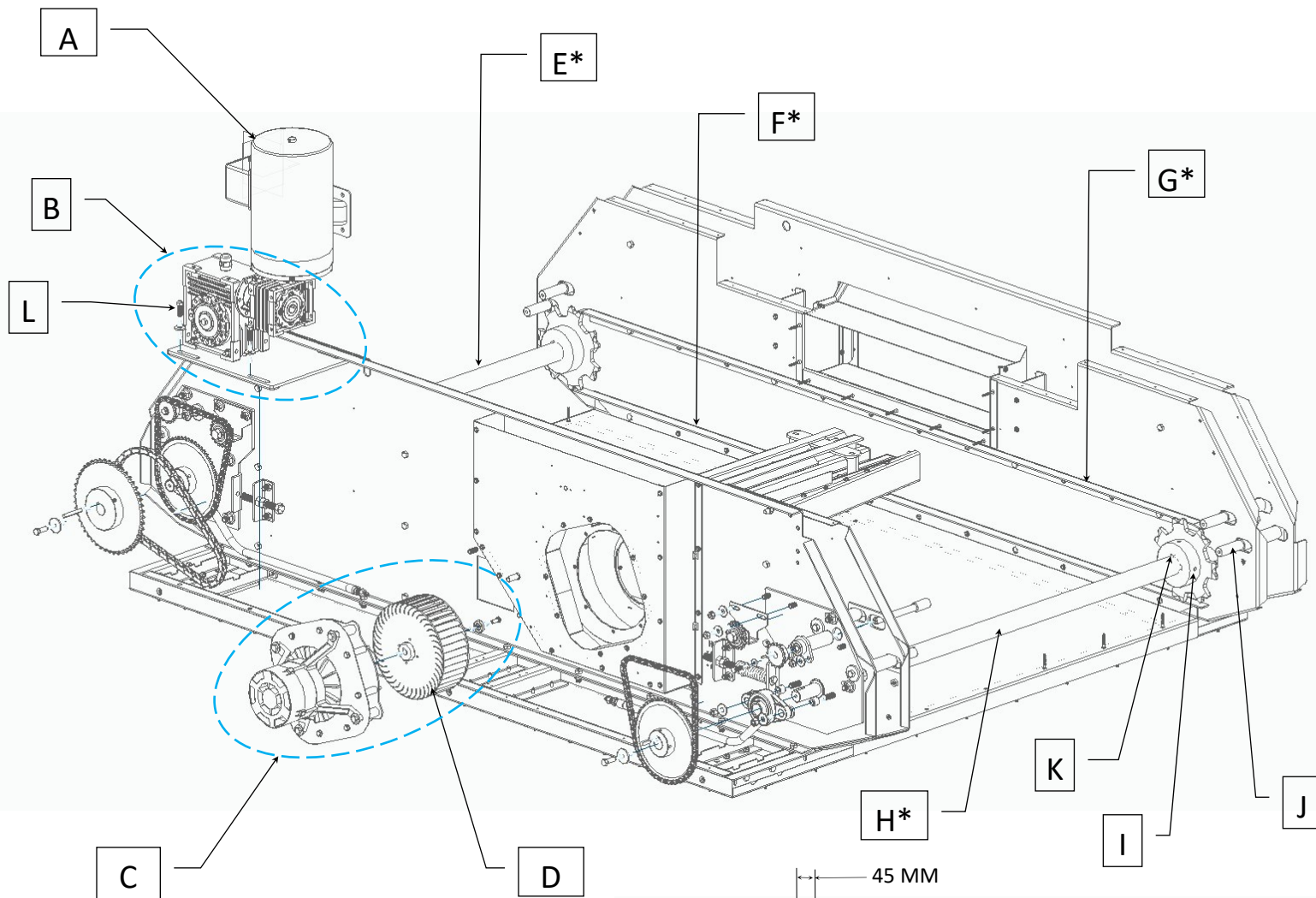

#	Part #	Description	Model
A	HR11-0058-A	CONVEYOR MOTOR	ALL
B	HR11-0085-A	GEARBOX	ALL
C	HR11-0061-A	CONVECTION FAN WITH MOTOR	ALL
D	HR11-0073-A	CONVECTION FAN	ALL
E*	HR02-0103-A	DRIVING SHAFT	HR-XX-22
E*	HR02-0003-A	DRIVING SHAFT	HR-XX-33
F*	HR01-0075-A	LOWER TRACK	HR-70-XX
F*	HR01-0522-A	LOWER TRACK	HR-93-XX
G*	HR01-0074-A	UPPER TRACK	HR-70-XX
G*	HR01-0517-A	UPPER TRACK	HR-93-XX
H*	HR02-0104-A	IDLER SHAFT	HR-XX-22
H*	HR02-0004-A	IDLER SHAFT	HR-XX-33
I	HR02-0062-B	MAIN CONVEYOR SPROCKET	ALL
J	HR02-0008-A	CONVEYOR ARM SUPPORT SHAFT	ALL
K	ME12-0522	MACHINE KEY STOCK 3/8" X 3/8" X 2"	ALL

\* MODEL SPECIFIC

Description

MECHANICS—1 of 4



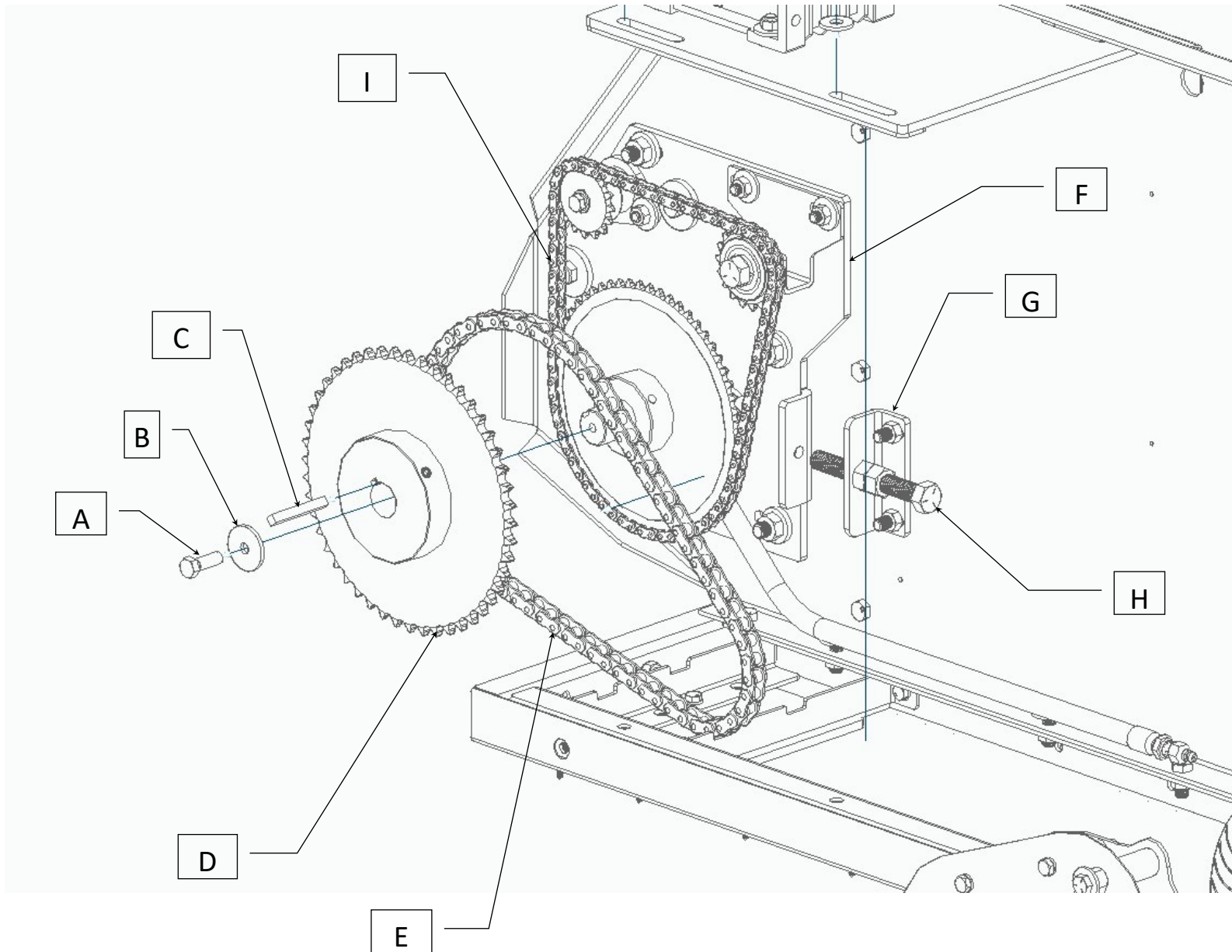

#	Part #	Description	Model
A	QU28-0079	BOLT 5/16-18 X 1"	ALL
B	HR01-0082-A	MAIN SHAFT WASHER	ALL
C	ME12-0523	MACHINE KEY STOCK 1/4" X 1/4" X 2"	ALL
D	HR11-0092-A	SPROCKET 40B48	ALL
E	HR11-0082-A	GEARBOX CHAIN	ALL
F	HR05-0108-B	CONVEYOR SHAFT SUPPORT (REAR LEFT)	ALL
G	HR04-0100-A	CHAIN TENSIONNER WELDED FLANGE	ALL
H	QU28-0558	BOLT 1/2-13 X 4"	ALL
I	HR11-0086-A	TRANSFERT CHAIN	ALL

\* MODEL SPECIFIC

Description

MECHANICS—2 of 4



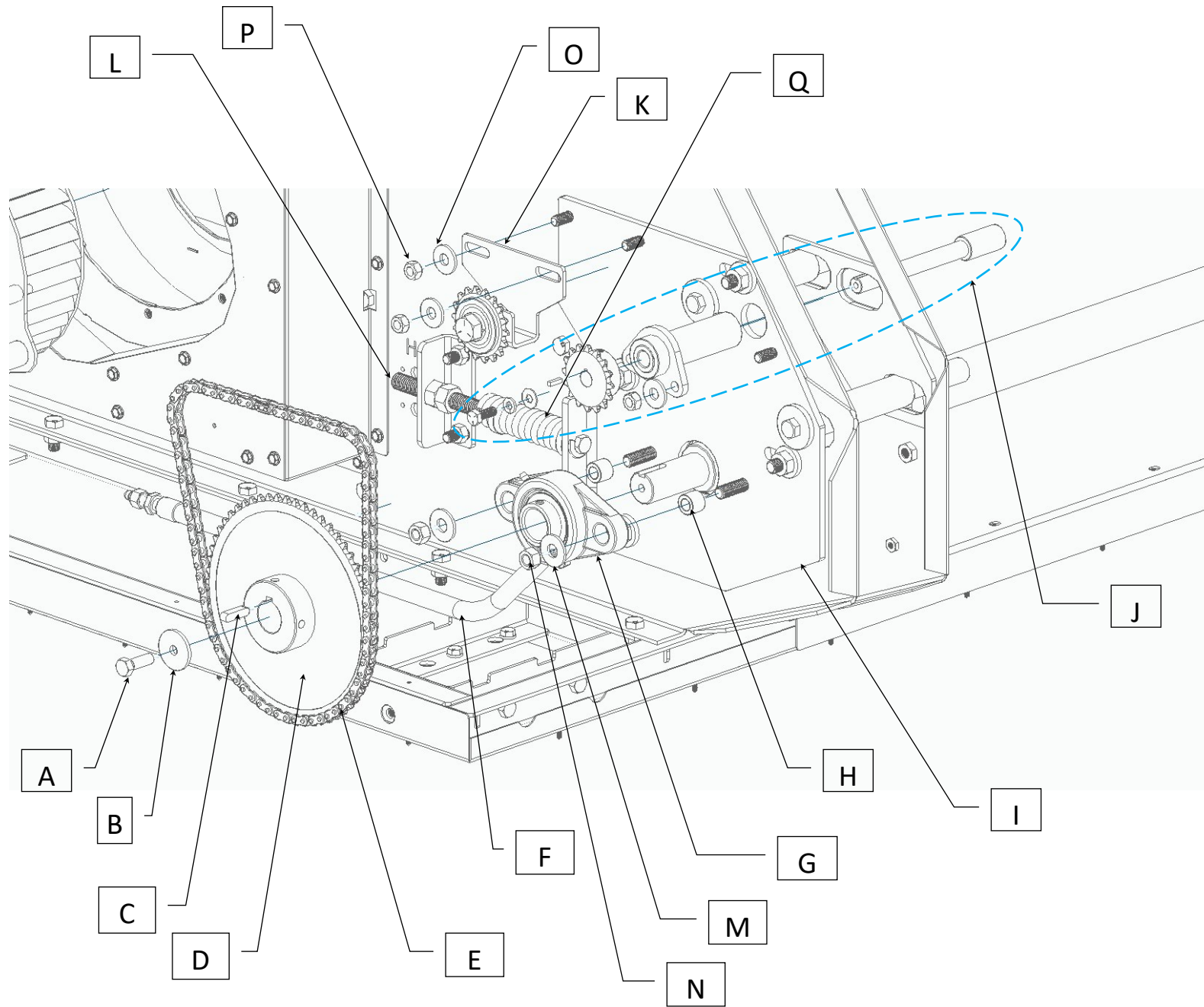

#	Part #	Description	Model
A	QU28-0079	HEX BOLT 5/16-18 X 1" ZINC PLATED	ALL
B	HR01-0082-A	MAIN SHAFT WASHER	ALL
C	ME12-0519	MACHINE KEY STOCK 1/4" X 1/4" X 1"	ALL
D	ME57-0198	SPROCKET 35B58	ALL
E	HR11-0086-A	TRANSFERT CHAIN #35	ALL
F	HR11-0078-A	GREASING TUBE	ALL
G	HR11-0072-A	HIGH TEMPERATURE BEARING	ALL
H	HR02-0009-A	BEARING SLEEVE	ALL
I	HR05-0107-B	CONVEYOR SHAFT SUPPORT (REAR RIGHT)	ALL
J	HR11-0045-A	CONVEYOR DRIVING SHAFT KIT	ALL
K	HR11-0093-A	CHAIN TENSIONNER	ALL
L	HR04-0023-A	SPRING TENSIONNER	ALL
M	QU28-0543	WASHER 3/8" ZINC PLATED	ALL
N	QU28-0009	NUT 3/8-16 ZINC PLATED	ALL
O	QU28-0540	WASHER 5/16" ZINC PLATED	ALL
P	QU28-0005	NUT 5/16-18 ZINC PLATED	ALL
Q	QU28-0156	SPRING	ALL

\*MODEL SPECIFIC

Description

MECHANICS—3 of 4





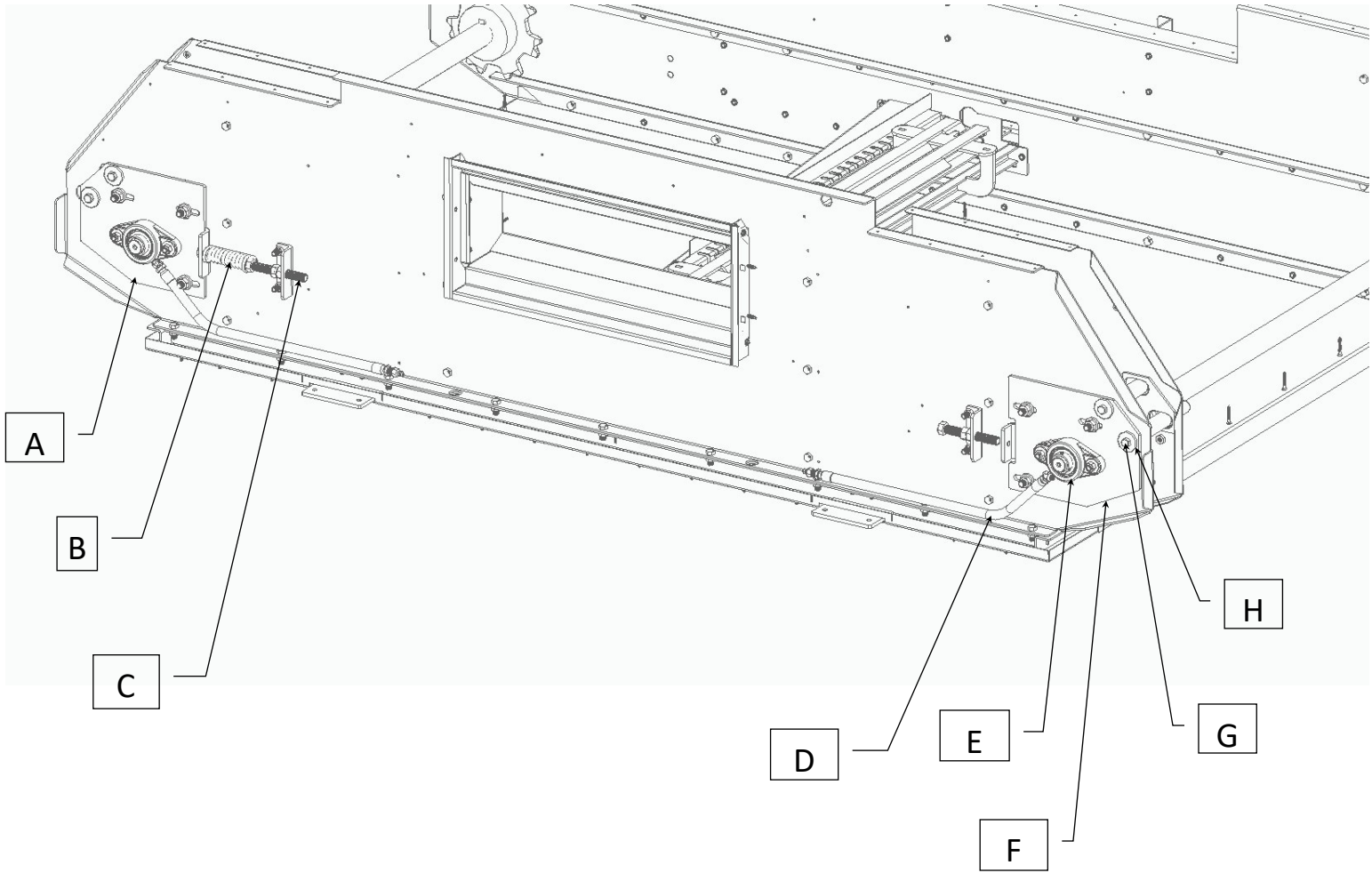

#	Part #	Description	Model
A	HR05-0106-B	CONVEYOR SHAFT SUPPORT (FRONT LEFT)	ALL
B	QU28-0156	SPRING	ALL
C	HR04-0023-A	SPRING TENSIONNER	ALL
D	HR11-0078-A	GREASE HOSE	ALL
E	HR11-0072-A	HIGH TEMPERATURE BEARING	ALL
F	HR05-0109-B	CONVEYOR SHAFT SUPPORT (FRONT RIGHT)	ALL
G	QU28-0421	HEX BOLT 3/8-16 X 3/4" ZINC PLATED	ALL
H	HR01-0085-A	CONVEYOR SUPPORT WASHER	ALL

\*MODEL SPECIFIC

Description  
 MECHANICS—4 of 4



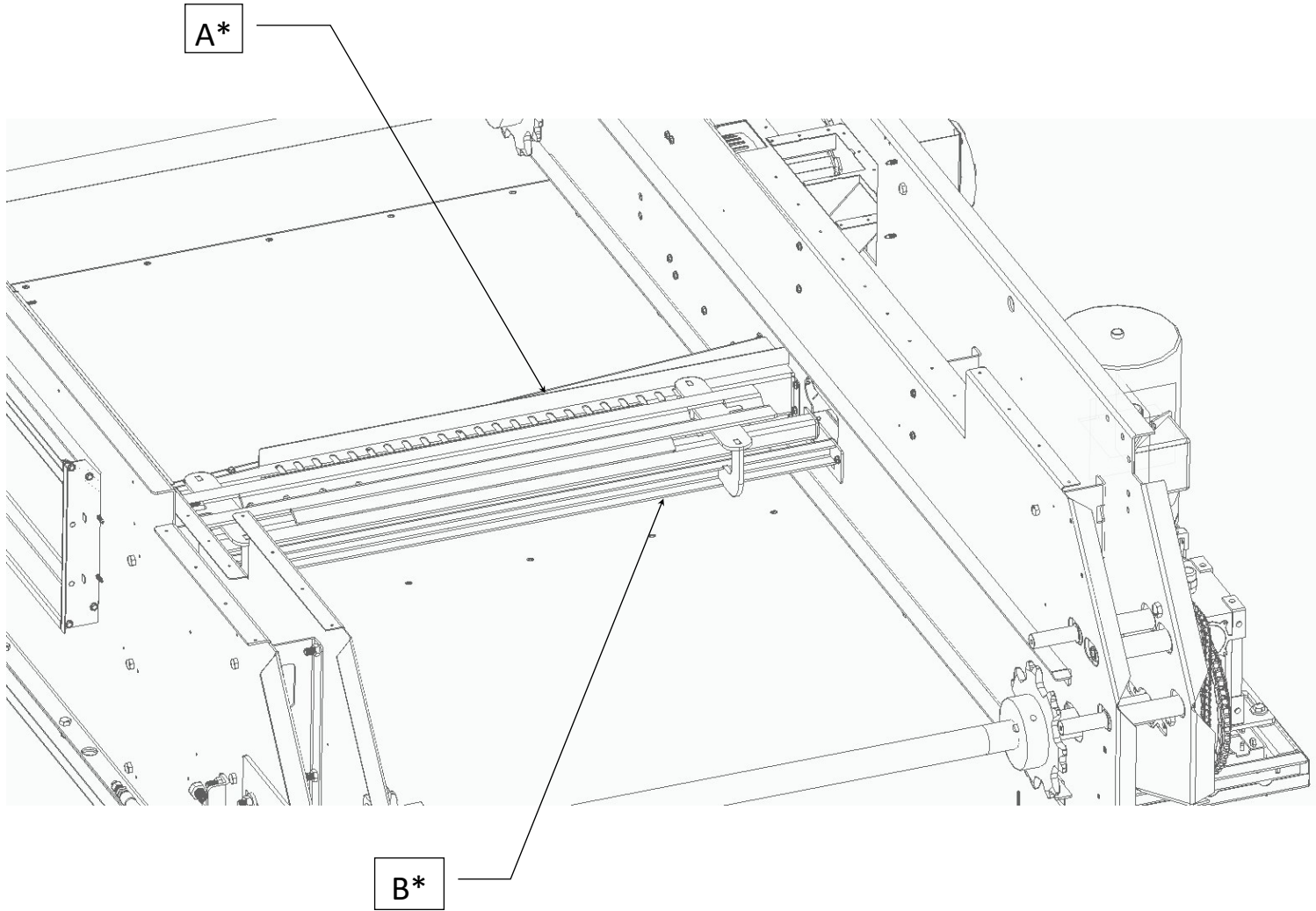

#	Part #	Description	Model
A*	HR11-0143-A	KIT SUCTION CHANEL HR0022	HR-XX-22
A*	HR11-0144-A	KIT SUCTION CHANEL HR0033	HR-XX-33
B*	HR11-0016-A	BURNER HOLDER AND DEFLECTOR	HR-XX-22
B*	HR11-0019-A	BURNER HOLDER AND DEFLECTOR	HR-XX-33

\*MODEL SPECIFIC

Description  
**BURNER SUPPORT AND SUCTION CHANNEL**



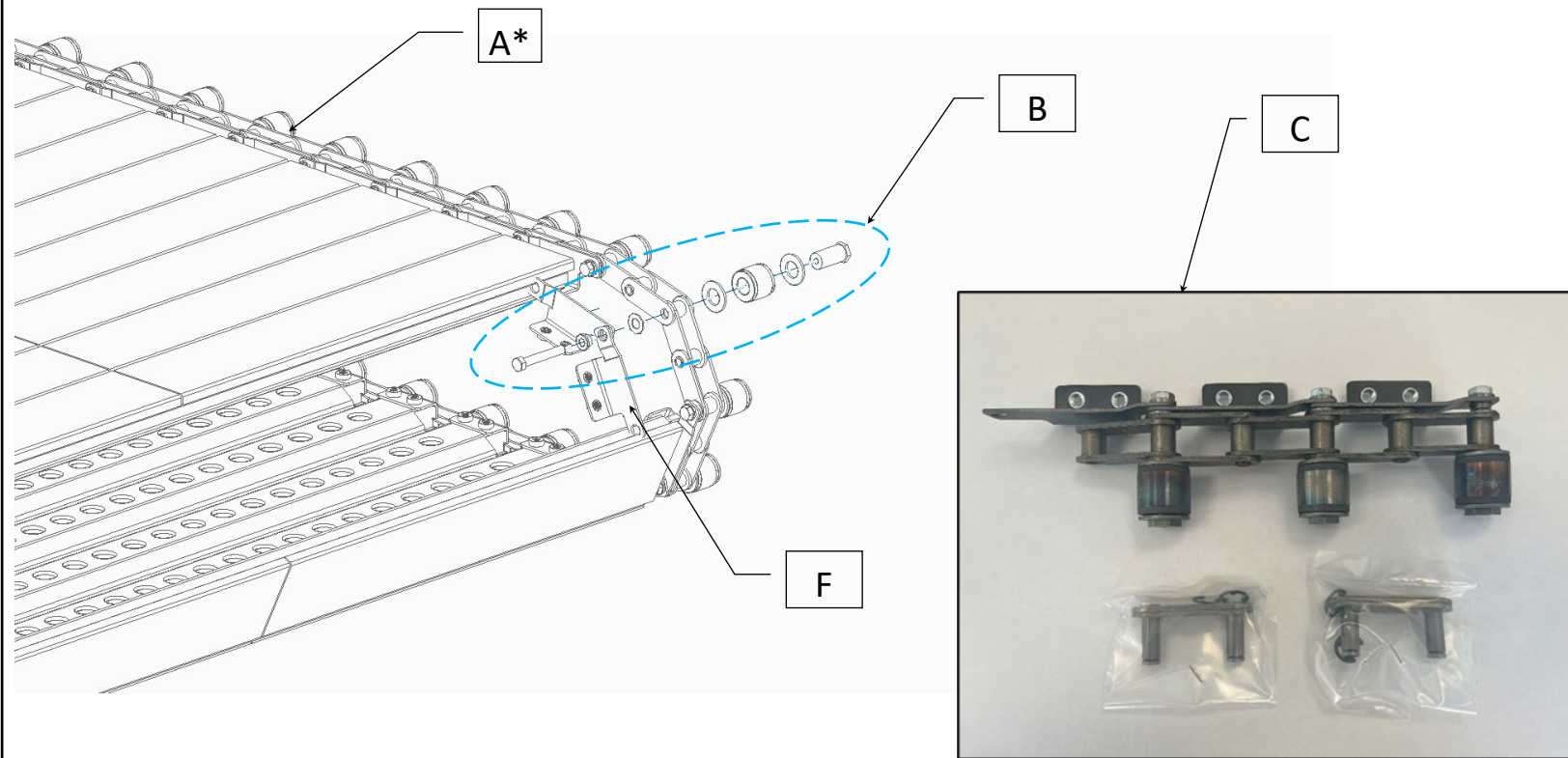
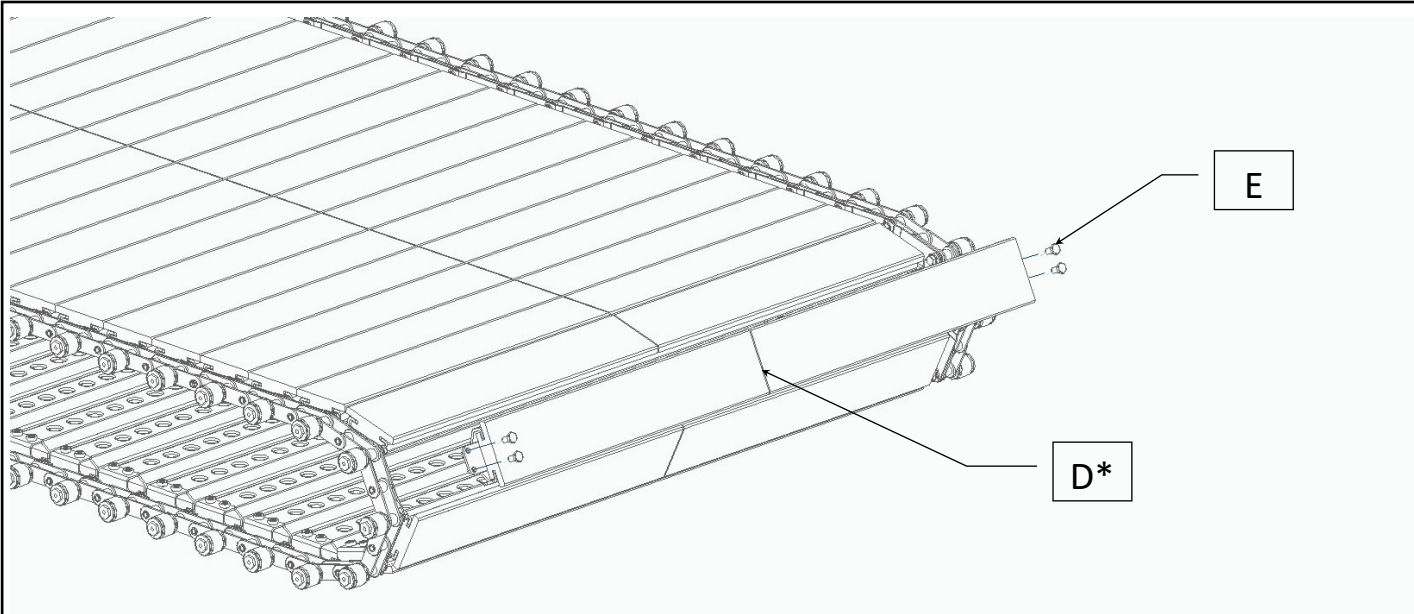

#	Part #	Description	Model
A*	HR11-0066-A	CHAIN ASSEMBLY	HR-70-XX
A*	HR11-0068-A	CHAIN ASSEMBLY	HR-93-XX
B	HR11-0001-A	BUSHING FOR CONVEYOR (PACK OF 5)	ALL
C	HR11-0130-A	2 LINKS CHAIN REPAIR KIT	ALL
D*	HR11-0071-A	SUPPORTS WITH STONES (PACK OF 3)	HR-XX-22
D*	HR11-0070-A	SUPPORTS WITH STONES (PACK OF 3)	HR-XX-33
E	051-0180	HEX BOLT 1/4-20 X 1/2" STAINLESS STEEL	ALL
F	HR05-0032-A	STONE SUPPORT BRACKET	ALL

\*MODEL SPECIFIC

Description

STONE CONVEYOR



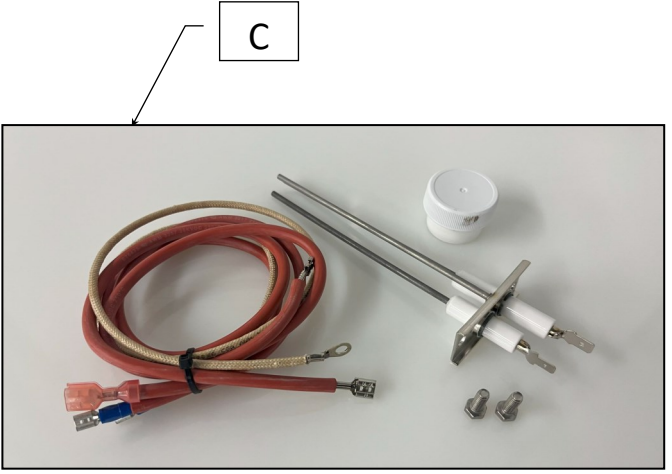
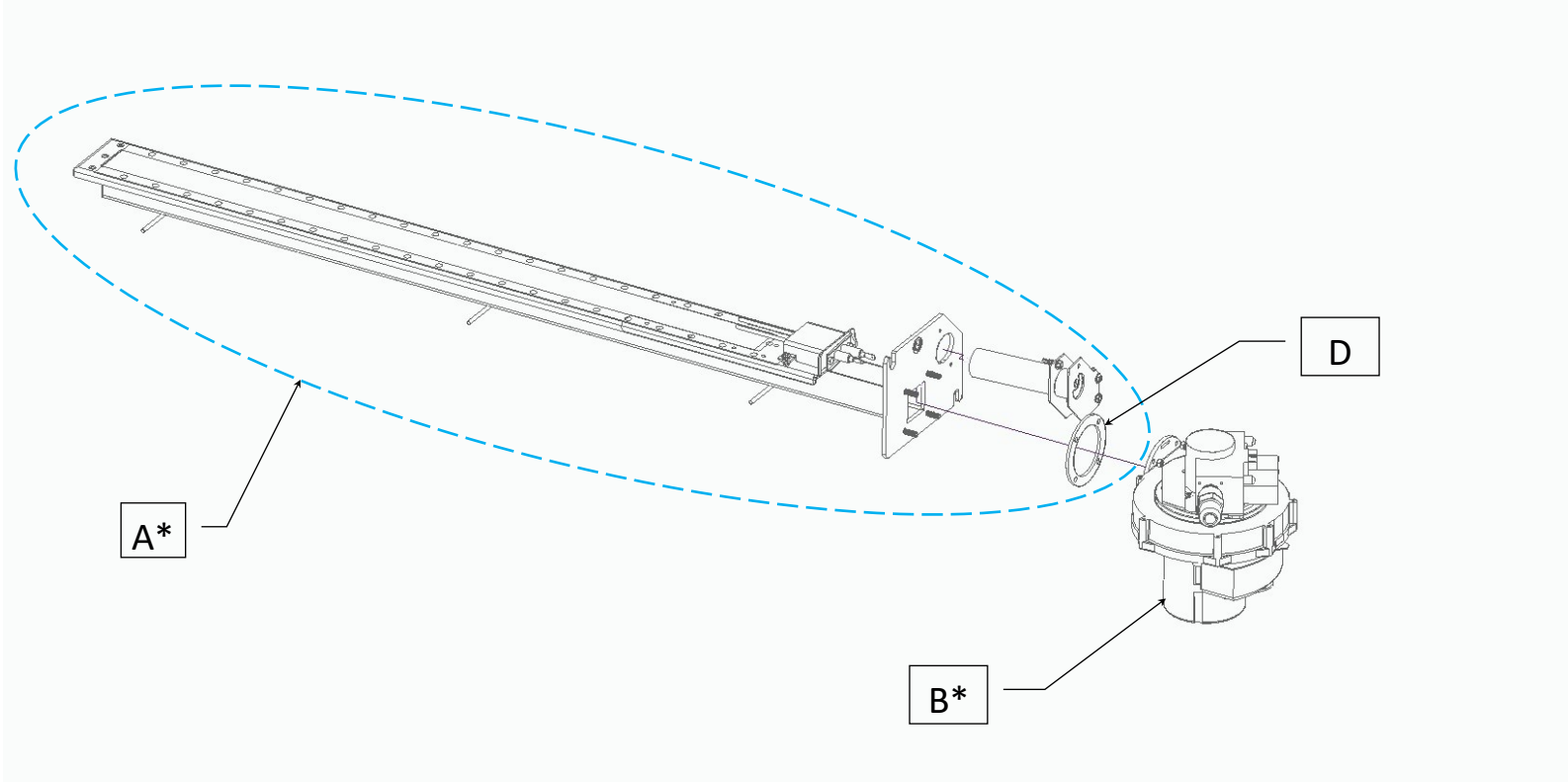

#	Part #	Description	Model
A*	HR11-0015-A	BURNER	HR-XX-22
A*	HR11-0018-A	BURNER	HR-XX-33
B*	HR11-0004-A	GAS BLOWER —NATURAL GAS	HR-XX-22
B*	HR11-0005-A	GAS BLOWER —PROPANE GAS	HR-XX-22
B*	HR11-0006-A	GAS BLOWER —NATURAL GAS	HR-XX-33
B*	HR11-0007-A	GAS BLOWER —PROPANE GAS	HR-XX-33
C	HR11-0028-A	FLAME ROD AND IGNITION CABLE	ALL
D	RE800418	GAS BLOWER GASKET	ALL

\*MODEL SPECIFIC

Description  
**GAS BURNER AND BLOWER VALVE**





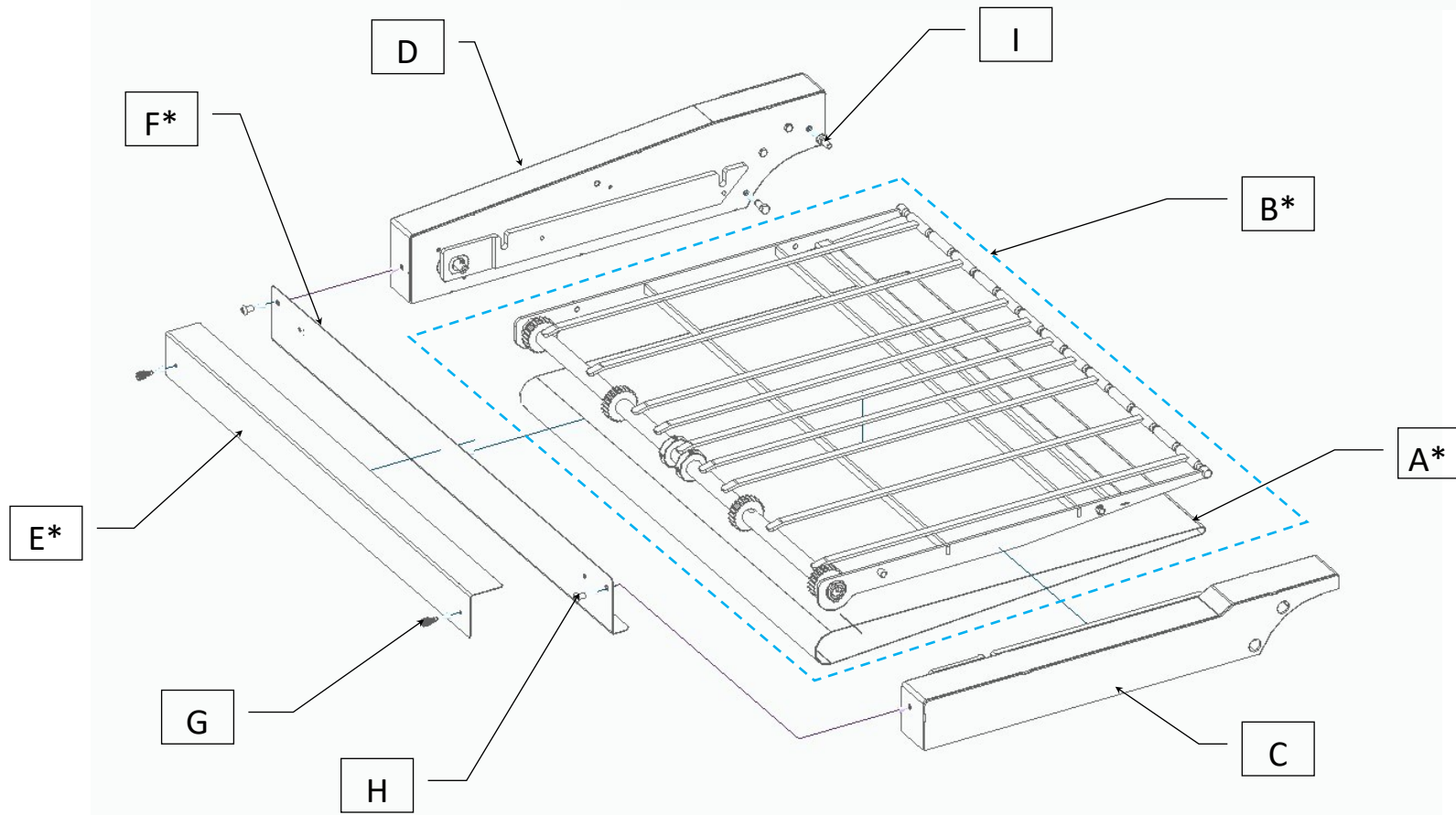
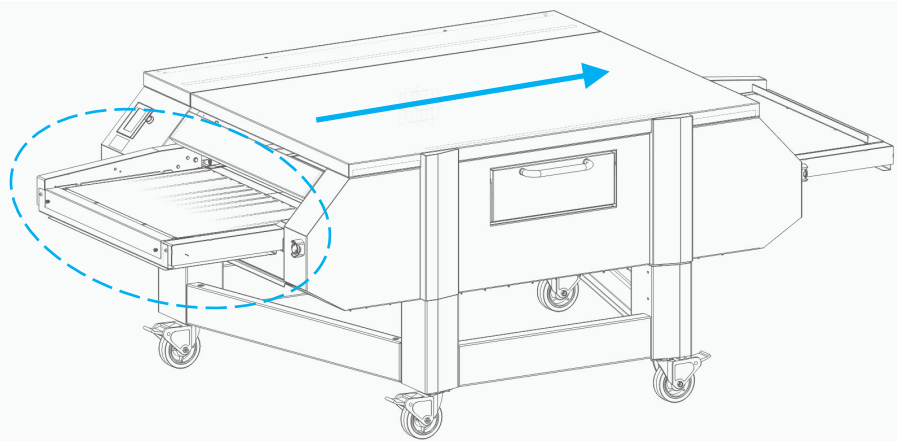

#	Part #	Description	Model
A*	HR11-0108-A	ENTRY CONVEYOR MESH	HR-XX-22
A*	HR11-0106-A	ENTRY CONVEYOR MESH	HR-XX-33
B*	HR11-0104-A	ENTRY CONVEYOR	HR-XX-22
B*	HR11-0102-A	ENTRY CONVEYOR	HR-XX-33
C	HR05-0198-A	LEFT ENTRY FRONT ARM	ALL
D	HR11-0110-A	LEFT ENTRY REAR ARM	ALL
E*	HR01B0017	ENTRY CONVEYOR FINITION BRACKET	HR-XX-22
E*	HR01B0009	ENTRY CONVEYOR FINITION BRACKET	HR-XX-33
F*	HR04-0187-A	CRUMB PAN SUPPORT	HR-XX-22
F*	HR04-0189-A	CRUMB PAN SUPPORT	HR-XX-33
G	HR11-0065-A	THUMB SCREW (PACK OF 8)	ALL
H	051-0186	BUTTON HEAD SCREW 1/4-20 X 1/2" SS	ALL
I	051-0300	HEX BOLT 5/16-18 X 3/4" STAINLESS	ALL

\*MODEL SPECIFIC



Description  
**LEFT ENTRY CONVEYOR**





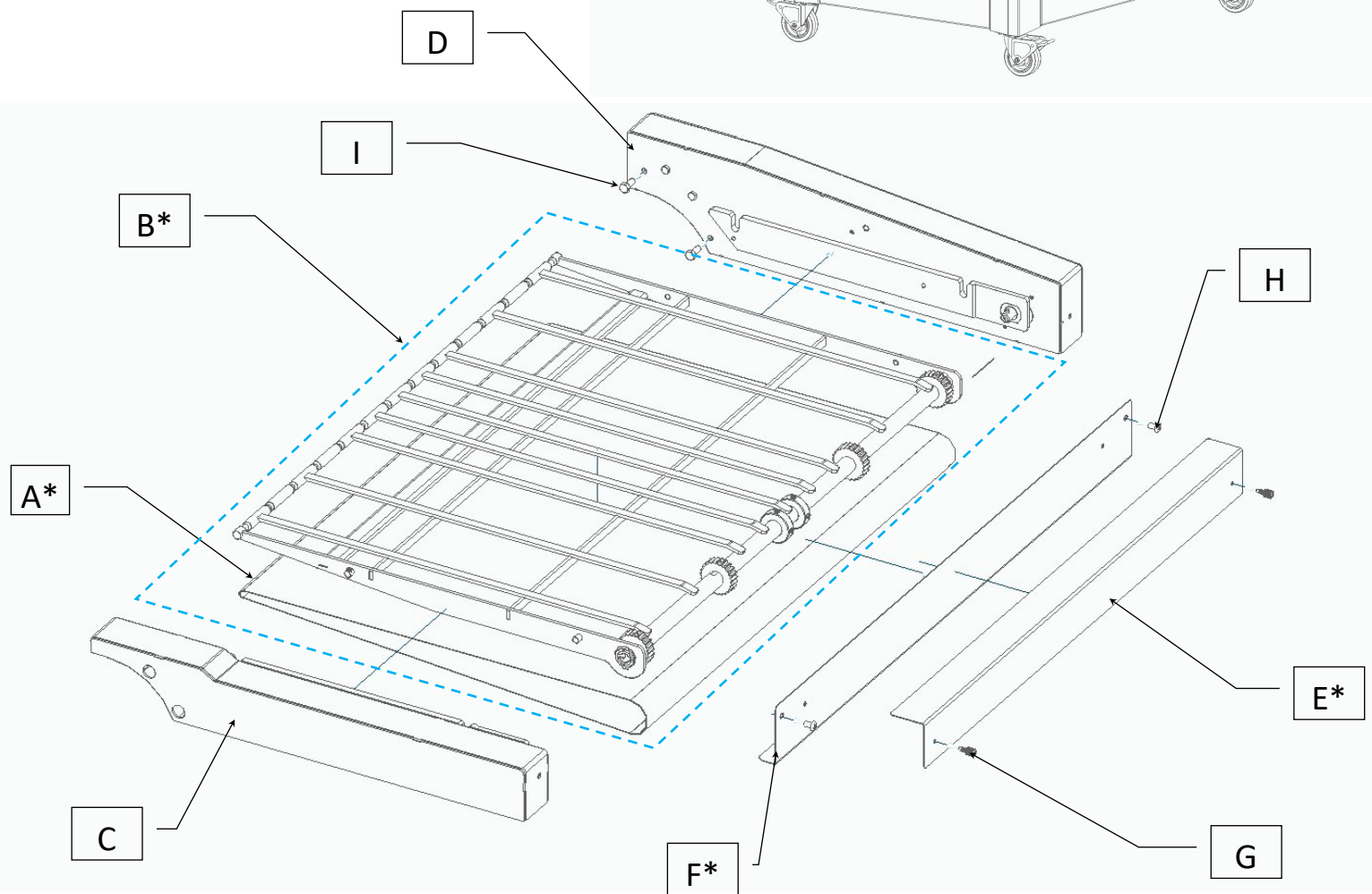
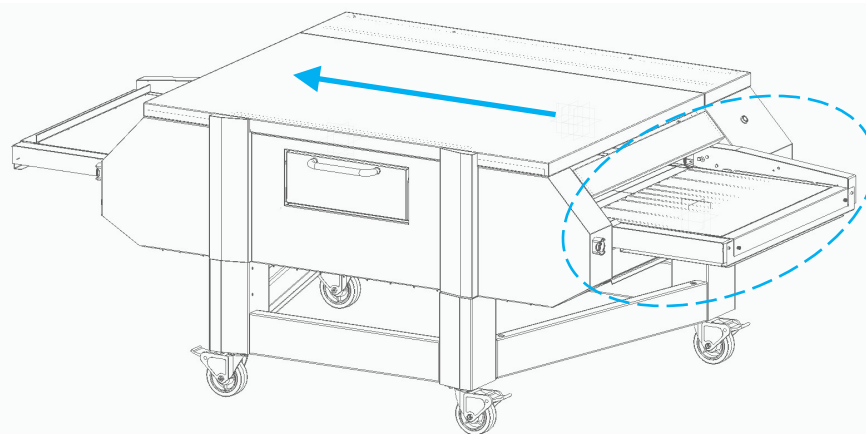

#	Part #	Description	Model
A*	HR11-0108-A	ENTRY CONVEYOR MESH	HR-XX-22
A*	HR11-0106-A	ENTRY CONVEYOR MESH	HR-XX-33
B*	HR11-0104-A	ENTRY CONVEYOR	HR-XX-22
B*	HR11-0102-A	ENTRY CONVEYOR	HR-XX-33
C	HR05-0216-A	RIGHT ENTRY FRONT ARM	ALL
D	HR11-0112-A	RIGHT ENTRY REAR ARM	ALL
E*	HR01B0017	ENTRY CONVEYOR FINITION BRACKET	HR-XX-22
E*	HR01B0009	ENTRY CONVEYOR FINITION BRACKET	HR-XX-33
F*	HR04-0187-A	CRUMB PAN SUPPORT	HR-XX-22
F*	HR04-0189-A	CRUMB PAN SUPPORT	HR-XX-33
G	HR11-0065-A	THUMB SCREW (PACK OF 8)	ALL
H	051-0186	BUTTON HEAD SCREW 1/4-20 X 1/2" SS	ALL
I	051-0300	HEX BOLT 5/16-18 X 3/4" STAINLESS	ALL

\*MODEL SPECIFIC



Description

**RIGHT ENTRY CONVEYOR**



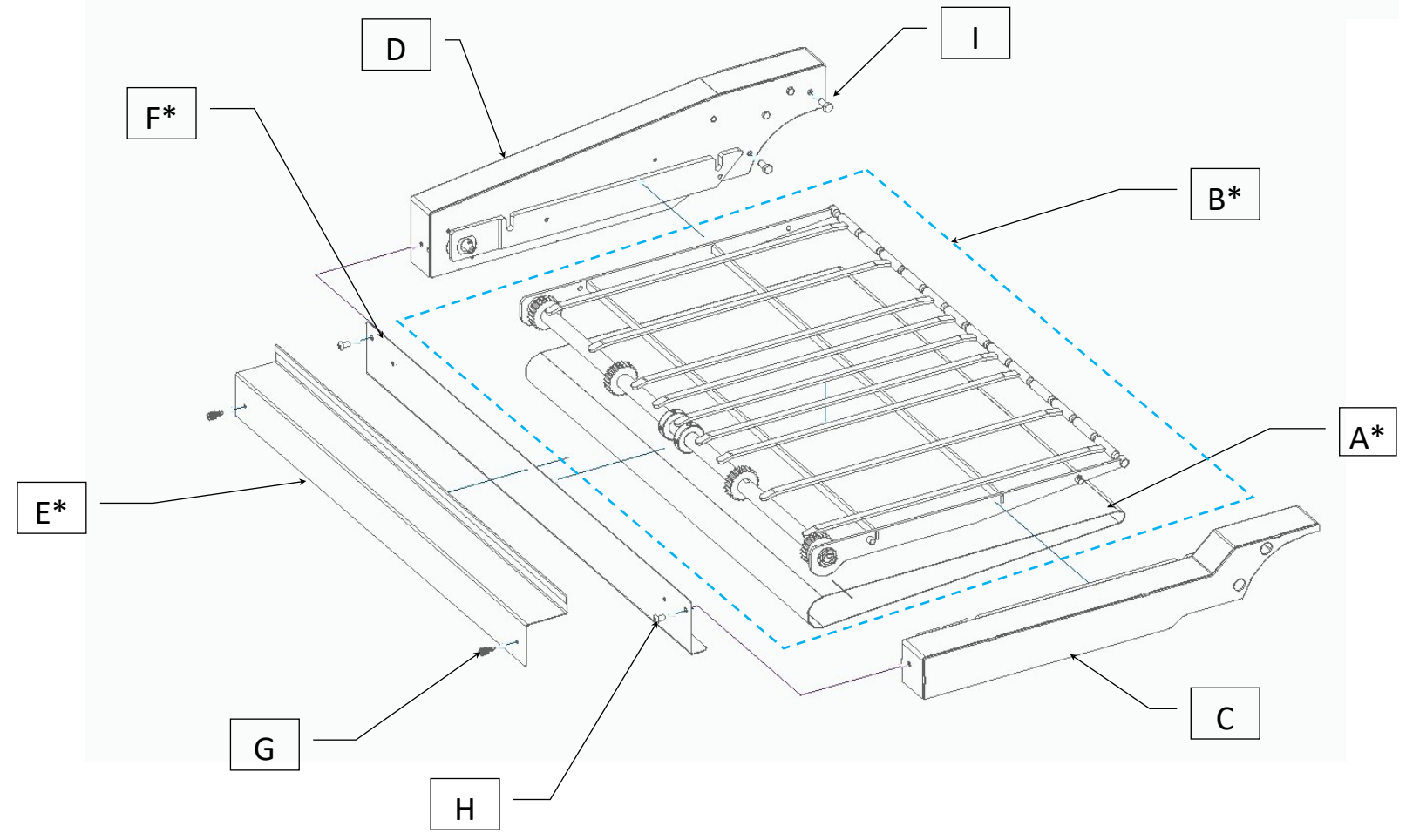
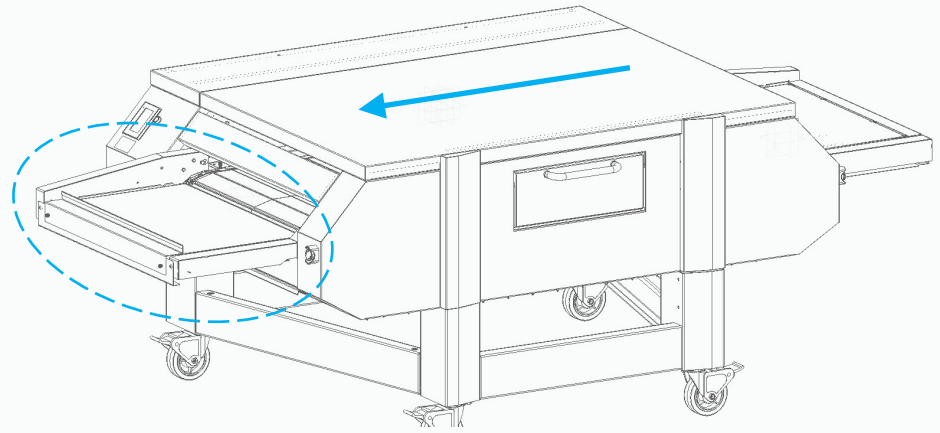

#	Part #	Description	Model
A*	HR11-0109-A	EXIT CONVEYOR MESH	HR-XX-22
A*	HR11-0107-A	EXIT CONVEYOR MESH	HR-XX-33
B*	HR11-0105-A	EXIT CONVEYOR	HR-XX-22
B*	HR11-0103-A	EXIT CONVEYOR	HR-XX-33
C	HR05B0064	LEFT EXIT FRONT ARM	ALL
D	HR11-0113-A	LEFT EXIT REAR ARM	ALL
E*	HR01A0260	EXIT CONVEYOR STOPPER	HR-XX-22
E*	HR01B0177	EXIT CONVEYOR STOPPER	HR-XX-33
F*	HR04-0187-A	CRUMB PAN SUPPORT	HR-XX-22
F*	HR04-0189-A	CRUMB PAN SUPPORT	HR-XX-33
G	HR11-0065-A	THUMB SCREW (PACK OF 8)	ALL
H	051-0186	BUTTON HEAD SCREW 1/4-20 X 1/2" SS	ALL
I	051-0300	HEX BOLT 5/16-18 X 3/4" STAINLESS	ALL

\*MODEL SPECIFIC

Description  
LEFT EXIT CONVEYOR



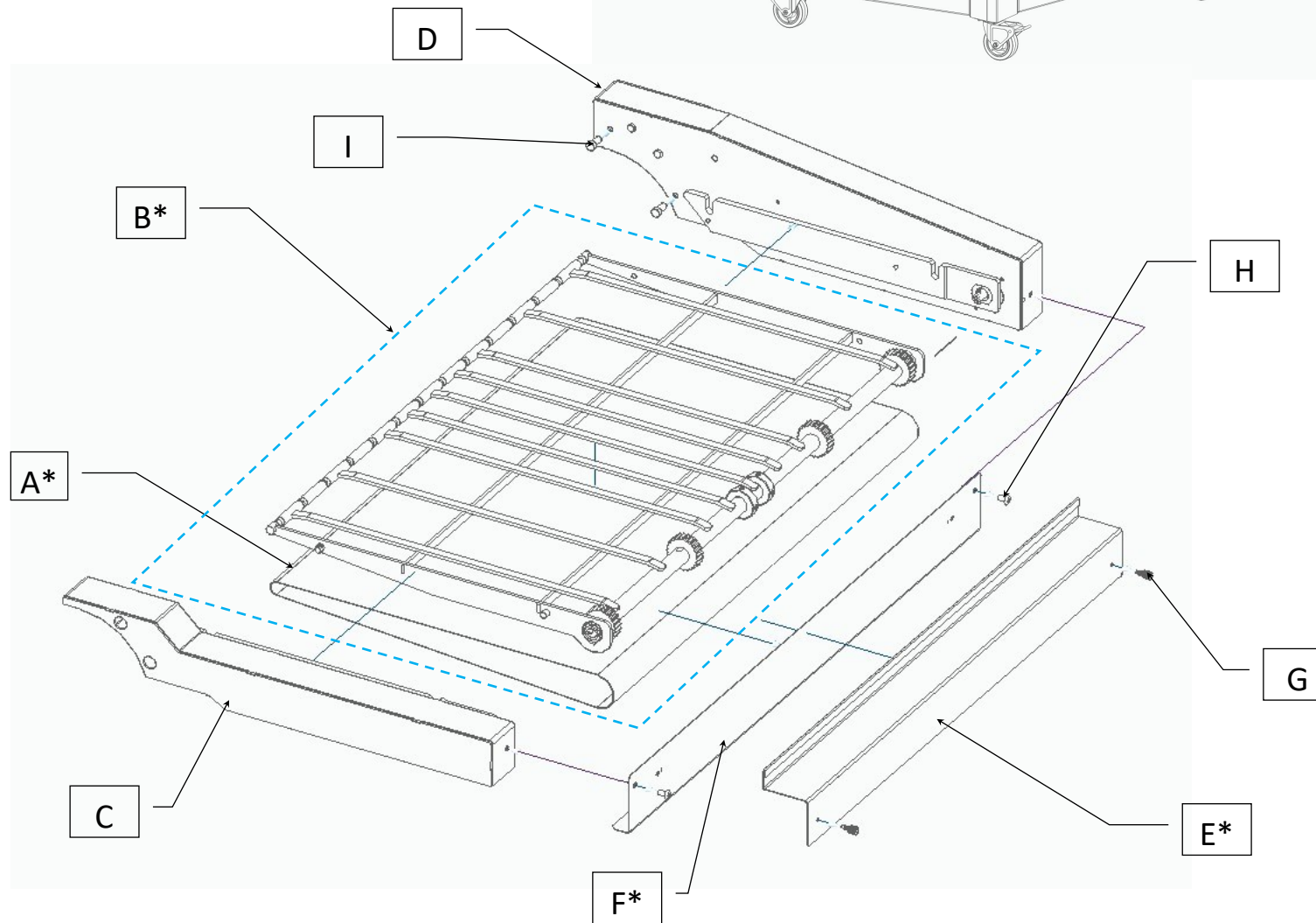
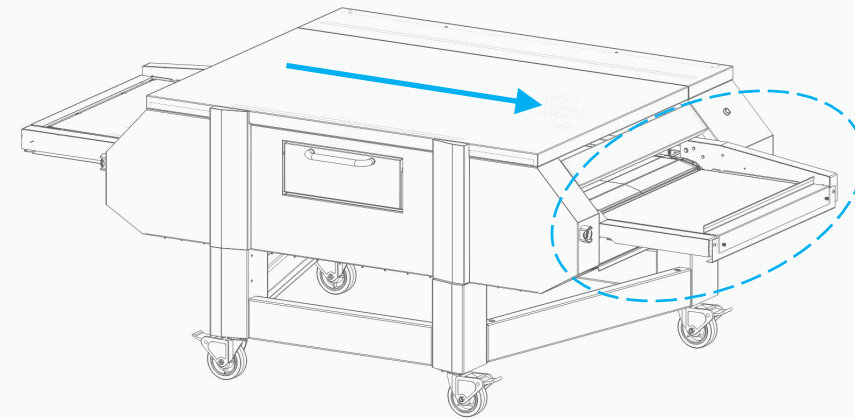

#	Part #	Description	Model
A*	HR11-0109-A	EXIT CONVEYOR MESH	HR-XX-22
A*	HR11-0107-A	EXIT CONVEYOR MESH	HR-XX-33
B*	HR11-0105-A	EXIT CONVEYOR	HR-XX-22
B*	HR11-0103-A	EXIT CONVEYOR	HR-XX-33
C	HR05B0059	RIGHT EXIT FRONT ARM	ALL
D	HR11-0111-A	RIGHT EXIT REAR ARM	ALL
E*	HR01A0260	EXIT CONVEYOR STOPPER	HR-XX-22
E*	HR01B0177	EXIT CONVEYOR STOPPER	HR-XX-33
F*	HR04-0187-A	CRUMB PAN SUPPORT	HR-XX-22
F*	HR04-0189-A	CRUMB PAN SUPPORT	HR-XX-33
G	HR11-0065-A	THUMB SCREW (PACK OF 8)	ALL
H	051-0186	BUTTON HEAD SCREW 1/4-20 X 1/2" SS	ALL
I	051-0300	HEX BOLT 5/16-18 X 3/4" STAINLESS	ALL

\*MODEL SPECIFIC

Description

RIGHT EXIT CONVEYOR



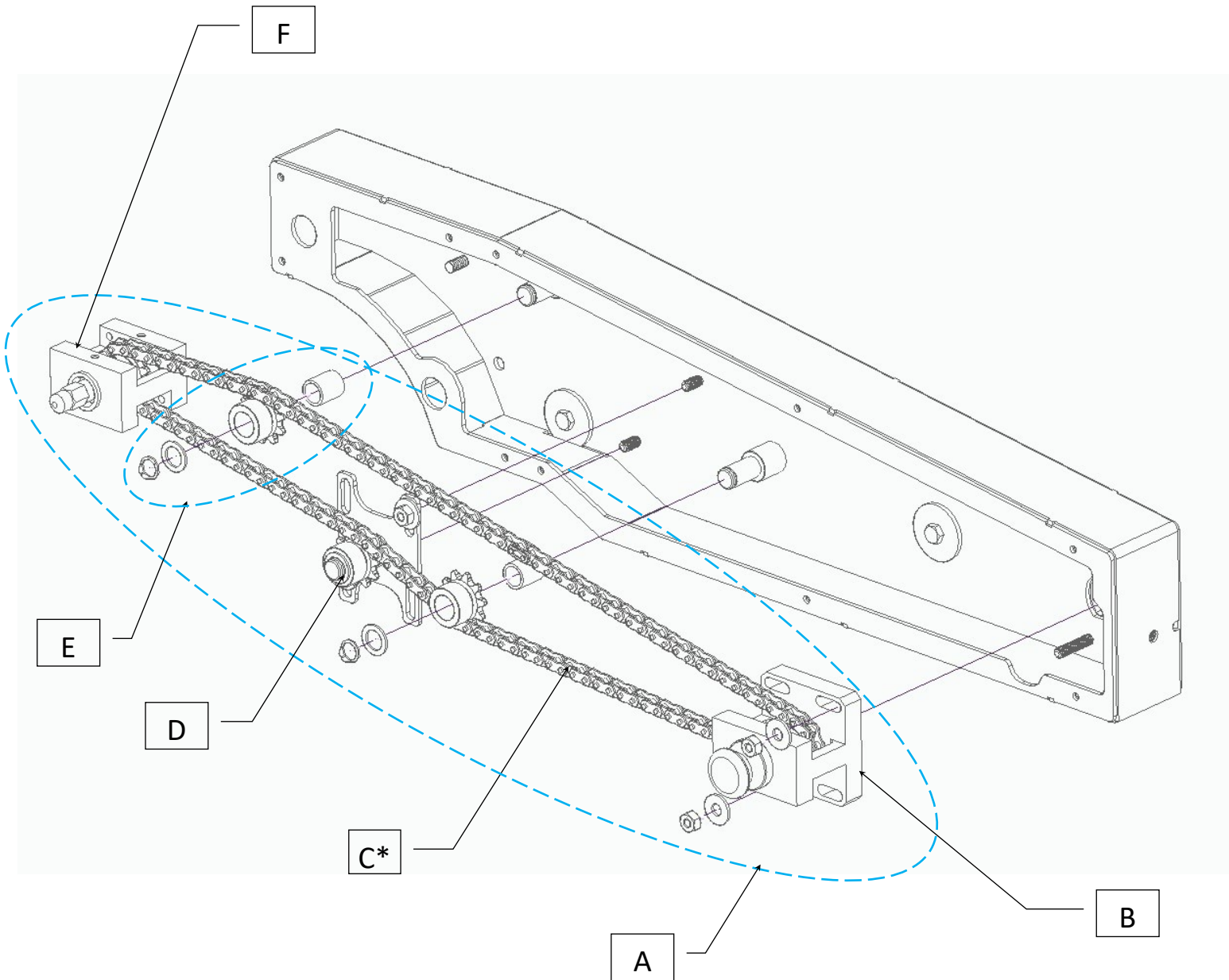

#	Part #	Description	Model
A	HR11-0119-A	ENTRY EXIT CONVEYOR ARM COMPONENTS	ALL
B	HR11-0096-A	KNOB WITH SPROCKET	ALL
C*	HR11-0084-A	ENTRY ARM CHAIN #35 WITH LINK	ENTRY
C*	HR11-0083-A	EXIT ARM CHAIN #35 WITH LINK	EXIT
D	HR11-0094-A	ARM CHAIN TENSIONNER	ALL
E	HR11-0095-A	ARM IDLING SPROCKET	ALL
F	HR11-0045-A	CONVEYOR DRIVING SHAFT KIT	ALL

\*MODEL SPECIFIC

Description

CONVEYOR ARM MECHANIC





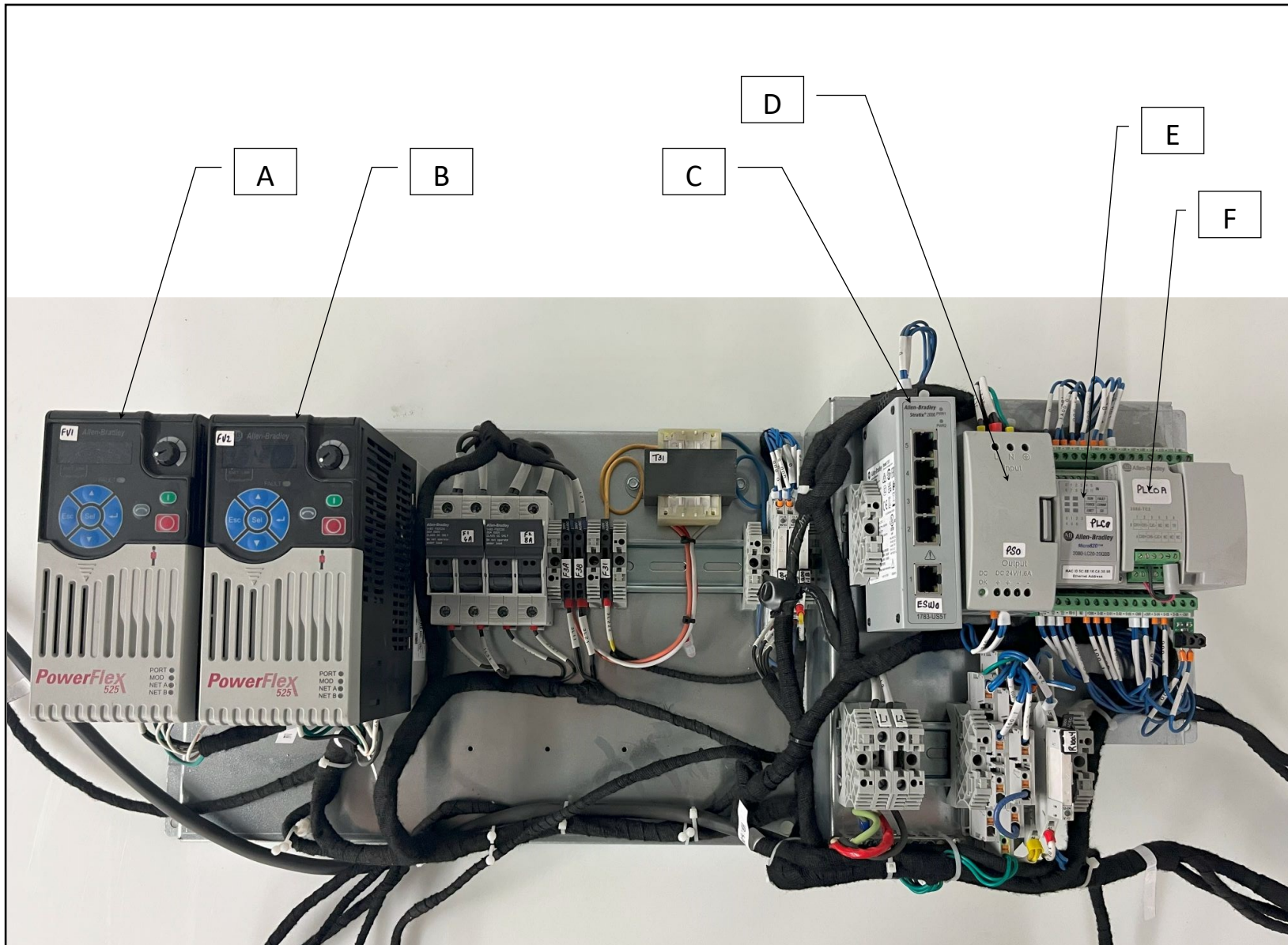

#	Part #	Description	Model
A	HR11-0053-A	VARIABLE FREQUENCY DRIVE 0.5HP (CONVEYOR)	ALL
B	HR11-0054-A	VARIABLE FREQUENCY DRIVE 1HP (CONVECTION FAN)	ALL
C	HR11-0100-A	ETHERNET MODULE	ALL
D	HR11-0101-A	24V POWER SUPPLY	ALL
E	HR11-0055-A	PLC (INCLUDE HR11-0099-A)	ALL
F	HR11-0099-A	CARTRIDGE I/O THERMOCOUPLE	ALL

\*MODEL SPECIFIC

Description

ELECTRICAL PANEL (PAGE 1 OF 3)





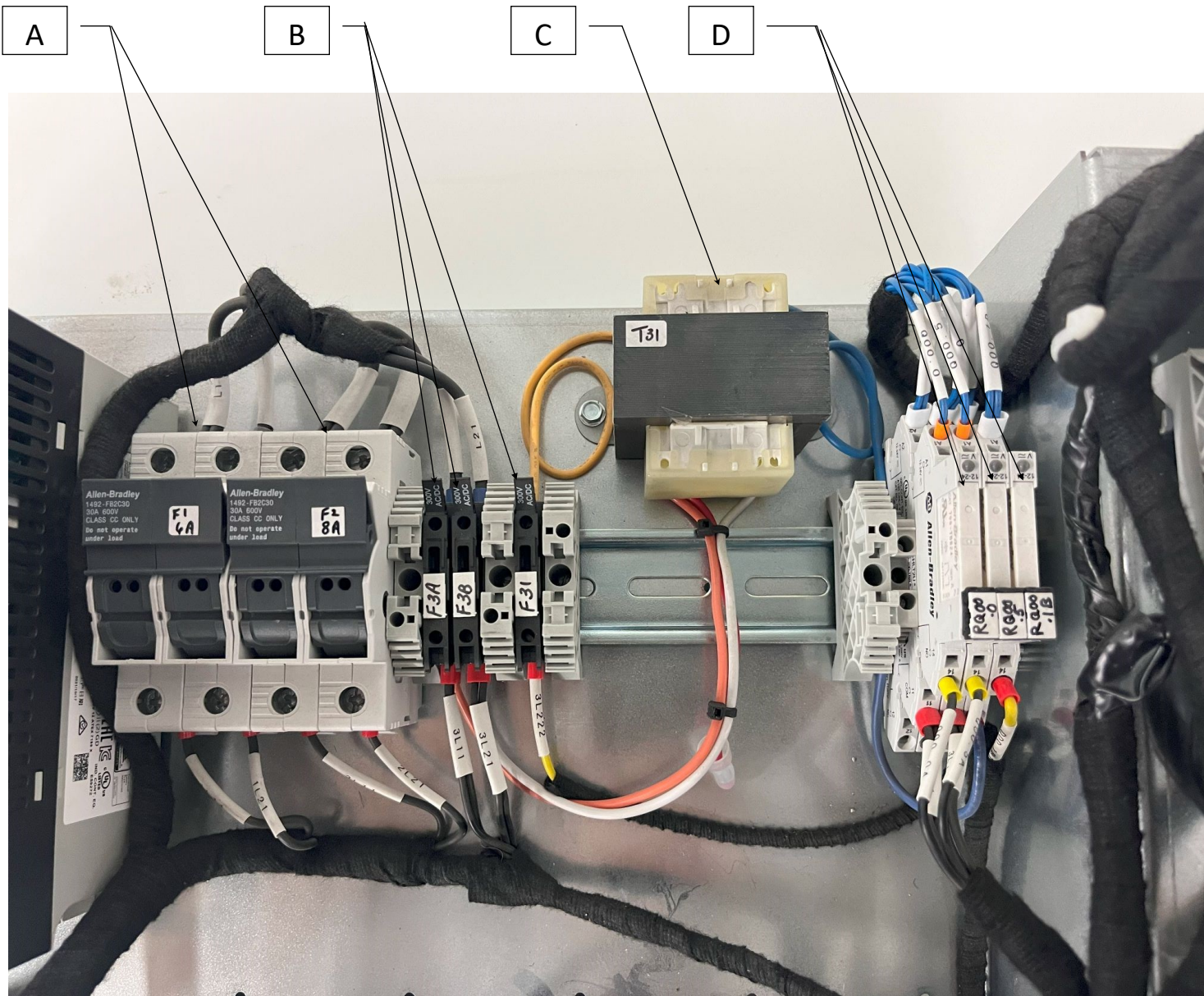

#	Part #	Description	Model
A	034-2001	FUSE HOLDER (CONVEYOR AND FAN)	ALL
B	034-2003	FUSE HOLDER	ALL
C	HR11-0079-A	TRANSFO 208/240V—24VAC	ALL
D	HR11-0088-A	24V RELAY	ALL

\*MODEL SPECIFIC

Description

ELECTRICAL PANEL (PAGE 2 OF 3)



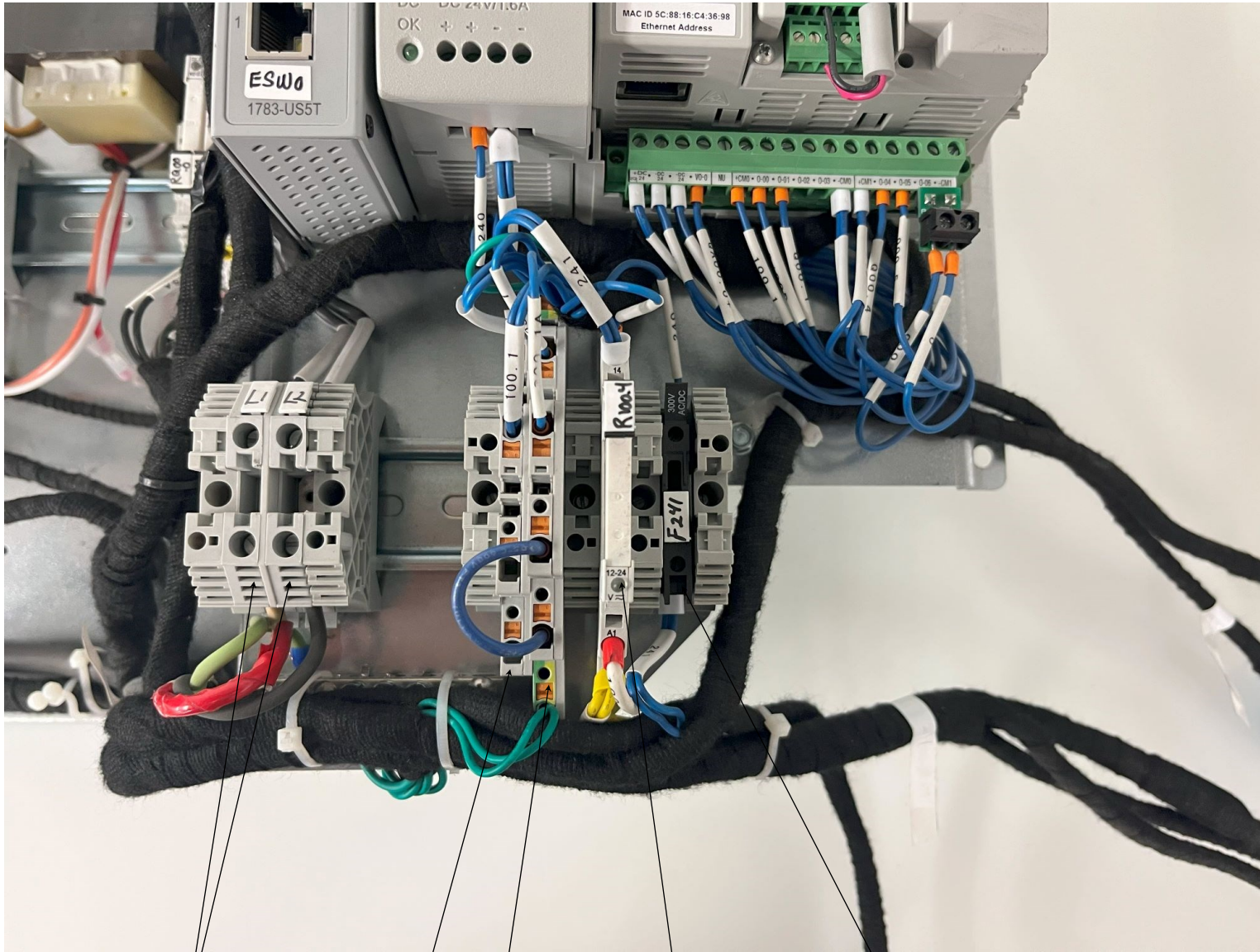

A

B

C

D

E

#	Part #	Description	Model
A	028-2010	SCREW TERMINAL	ALL
B	028-2000	2 LEVEL PUSH-IN TERMINAL	ALL
C	028-2006	3 LEVEL PUSH-IN TERMINAL	ALL
D	HR11-0088-A	24V RELAY	ALL
E	034-2003	FUSE HOLDER	ALL

\*MODEL SPECIFIC

Description

ELECTRICAL PANEL (PAGE 3 OF 3)







A



B



C



D



E



F

#	Part #	Description	Model
A	HR11-0091-A	ETHERNET CABLE KIT	ALL
B	HR11-0145-A	E-STOP WIRE KIT	ALL
C	HR11-0025-A	GAS BOLWER MOTOR CONTROL HARNESS	ALL
D	HR11-0050-A	POWER HARNESS	ALL
E	HR11-0051-A	AC CONTROL HARNESS	ALL
F	HR11-0052-A	DC CONTROL HARNESS	ALL

\*MODEL SPECIFIC

Description

CABLES, WIRES AND HARNESS





A



B

#	Part #	Description	Model
A	HR11-0098-A	FUSE KIT	ALL
B	HR11-0060-A	PLC AND HMI SOFTWARE	ALL

\*MODEL SPECIFIC

Description

FUSE AND SOFTWARE

