



HOT ROCKS

**Hot Rocks Oven GEN3 –PLC and HMI update guide**

FOR SUPPORT  
[service@hotrocksoven.com](mailto:service@hotrocksoven.com)

1 800 668-1883



# TABLE OF CONTENTS

Revisions .....	4
<b>1 Material needed .....</b>	<b>4</b>
<b>2 Log oven's current settings .....</b>	<b>5</b>
<b>3 Preparation before update.....</b>	<b>8</b>
3.1 Copying the files on USB KEY and micro SD card.....	8
3.2 Insert USB key and MicroSD card in the oven .....	11
<b>4 Perform the update .....</b>	<b>13</b>
4.1 PLC update .....	13
<b>5 Oven reconfiguration.....</b>	<b>16</b>
5.1 Remove the USB key and SD Card .....	16
5.2 Verify if the PLC and HMI version has been updated.....	16
5.3 Re-configure the oven.....	16

## Revisions

Revision	Date	Modifications
0	2022-03-17	Original version 15-0001
1	2022-03-18	General revision
3	2022-04-04	Minor translation corrections
4	2022-04-26	Add instruction purpose
5	2022-05-26	USB key procedure section 3

This instruction will show you how to get the oven up-to-date program version on the PLC and the HMI. The USB thumb drive contains the files of the latest version for the HMI and the PLC. Follow sequence from this procedure to gather information prior installing the new PLC or HMI. If it's not possible to get access to those pages, you will simply have to configure the HMI when the replacement is done.

## 1 Material needed

You need a microSD type card as well as a USB thumb drive. The SD card and thumb drive must have a maximum capacity of 2GB each.

Suggested Amazon link for 5 X microSD card with an USB adapter, click [HERE](#).

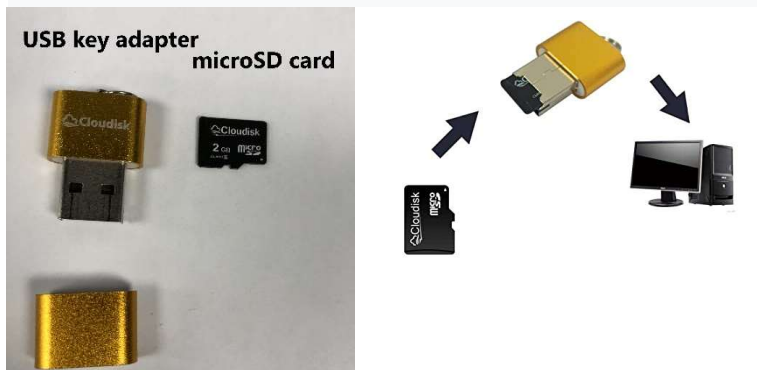

- Phillips # 2 or 3 screwdriver

## 2 Log oven's current settings

- Power-up the oven by turning on the main switch

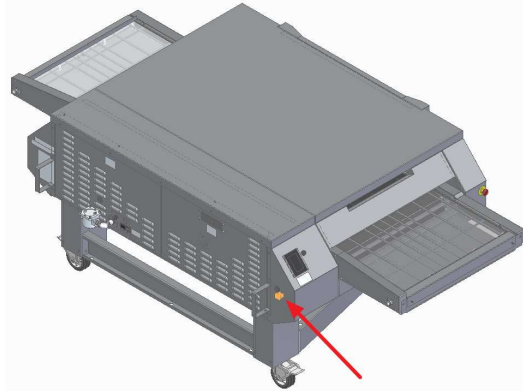

- Login technician mode;
  - On the main screen, click on “SYSTEM” menu and then on “USER” menu, and then on “LOGIN”

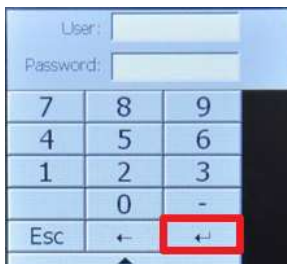
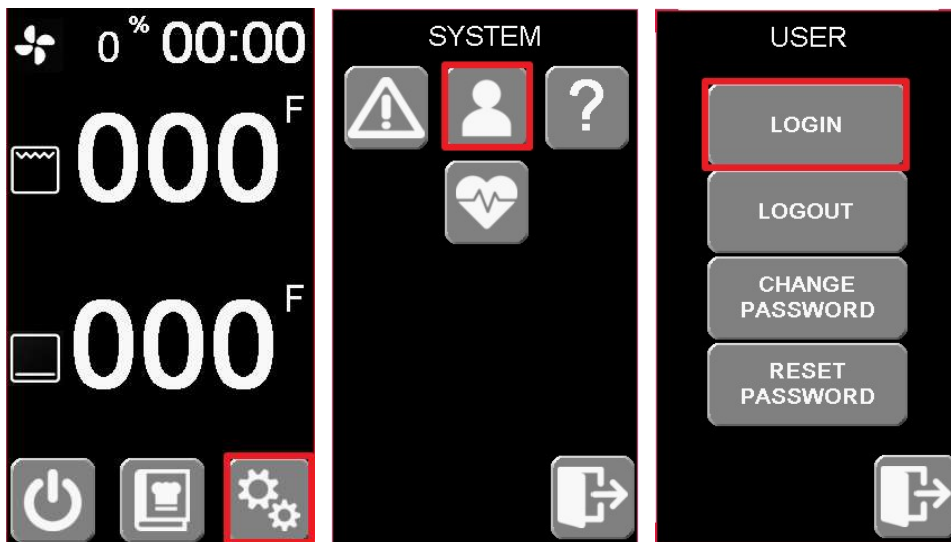

Enter;

- User: **2**
- Password: **911**

Then press enter

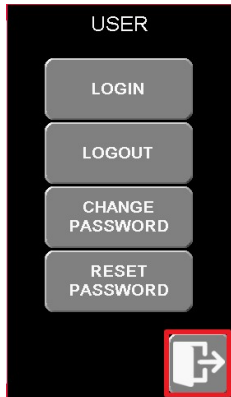

- Go back to the main screen by pressing back 2 times

On the main screen go in the “RECIPES” menu and write down or take pictures, then go back on the main screen;

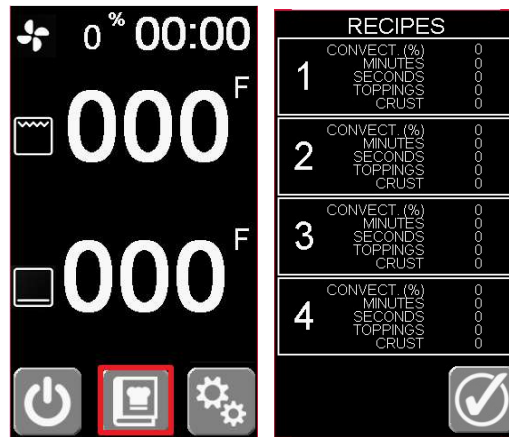

On the main screen go in “General Settings” menu and write down or take pictures and go back on the main screen;

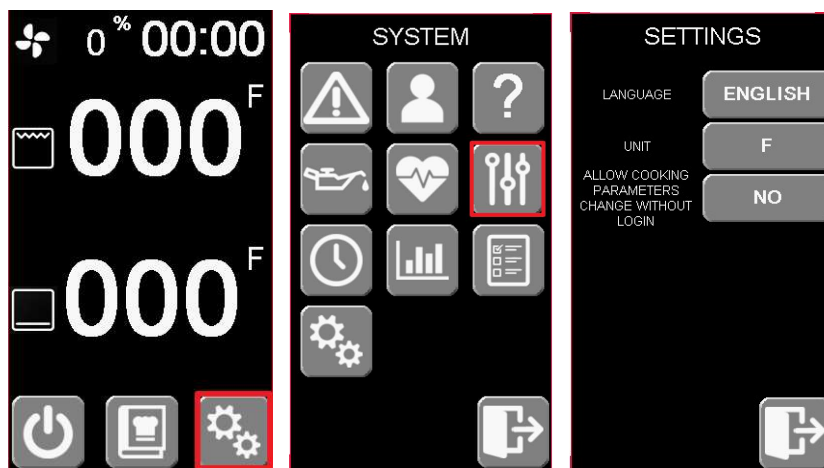

On the main screen, go in "Configuration" menu and write down or take pictures

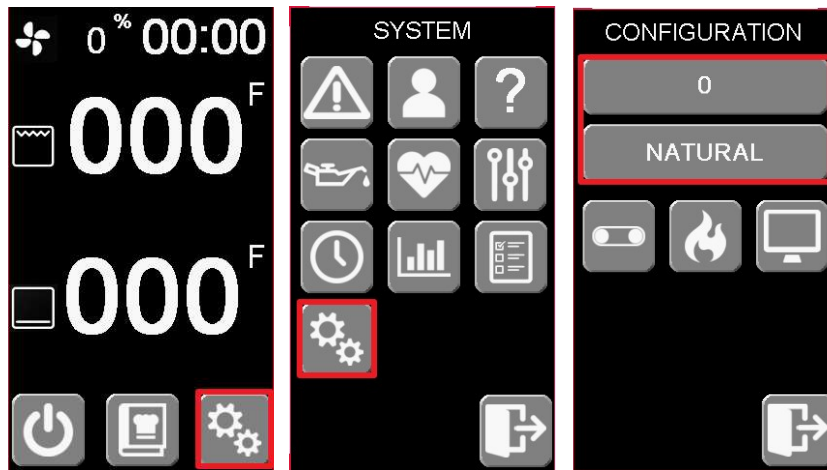

In the same "Configuration" menu, go in "Conveyor Settings" menu and write down or take pictures and then go back on the main screen;

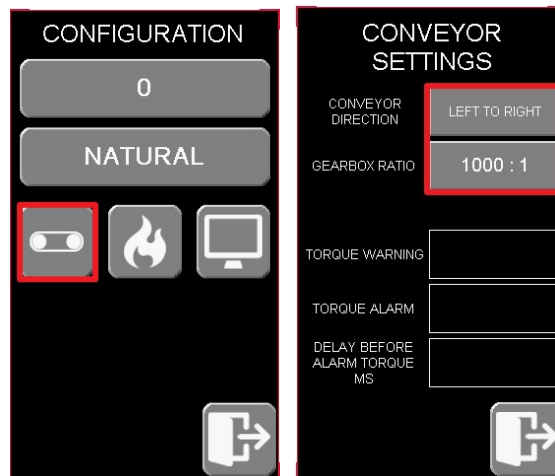

## 3 Preparation before update

### 3.1 Copying the files on USB KEY and micro SD card

Use a PC to copy the proper files on the SD card and keep only the proper ones on the USB key or microSD card.

First, you must have a USB key and microSD card formatted in FAT32. To do this, follow the instructions below.

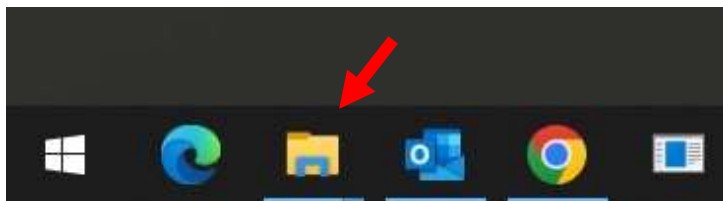

Click on the FILE EXPLORER icon near of the Windows ICON.

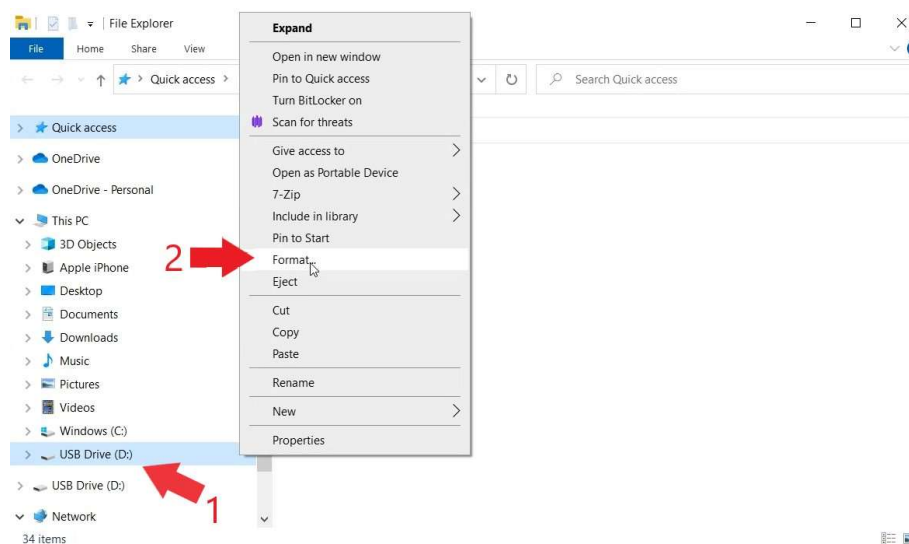

1 - Find your USB Drive on the left menu. Usually it's the letter (D:).

2- By clicking the right mouse button, a menu of options appears. Select the FORMAT menu.

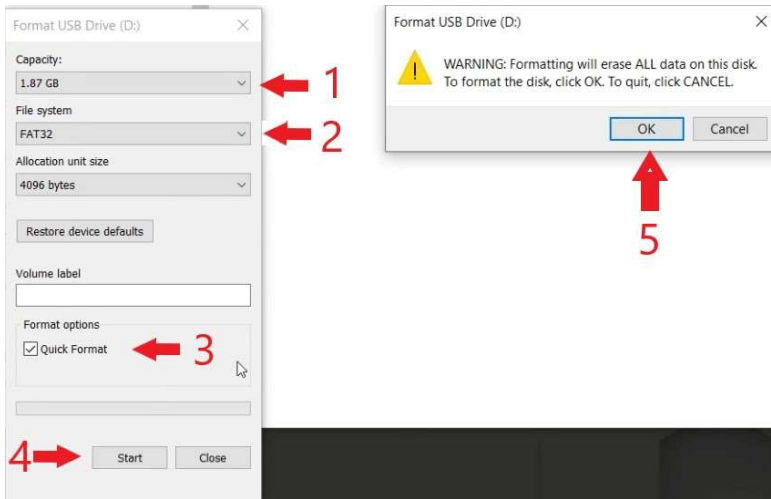

In the FORMAT menu.

- 1- This is the capacity of the USB key or microSD card.
- 2- Make sure FAT32 has been selected from the drop-down menu.
- 3- Check marks the QUICK FORMAT box.
- 4- When all is done, click START.
- 5- Click OK in the warning box that appeared.

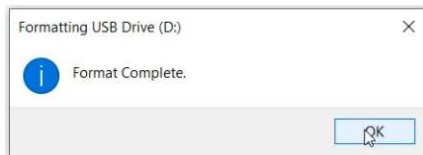

After some time, a window will appear to indicate that everything is complete. Click OK



To exit the FORMAT USB Drive menu, click on CLOSE

Get the latest software version, on the website. (Google Chrome was used for the walkthrough)  
<https://hotrocksoven.com/downloads/>



- 1- Click on the icon **Gen 3 latest software version**
- 2- A box appears in the left bottom corner, click on the arrow to see the menu.
- 3- Click on OPEN.

Put the microSD card in the USB port of the PC.

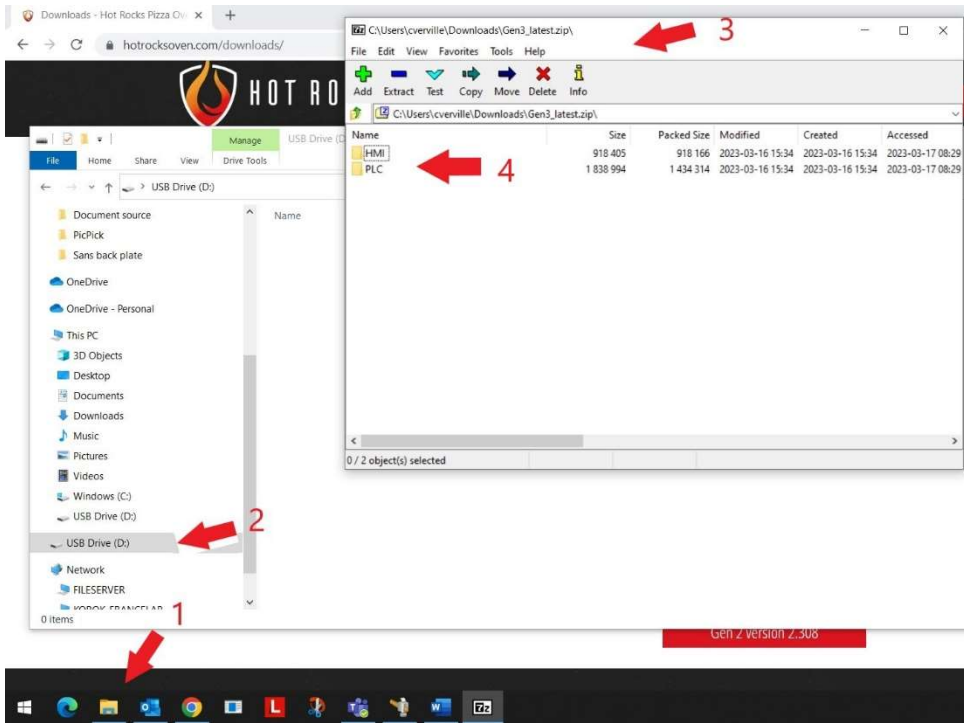

1-Click on the FILE EXPLORER icon.

2-Select the USB Drive.

3-Select the previously opened window of the latest version of the program file.

4-Double click on HMI to see the file to put on USB Key. Double click on PLC to see the files to put on the microSD card.

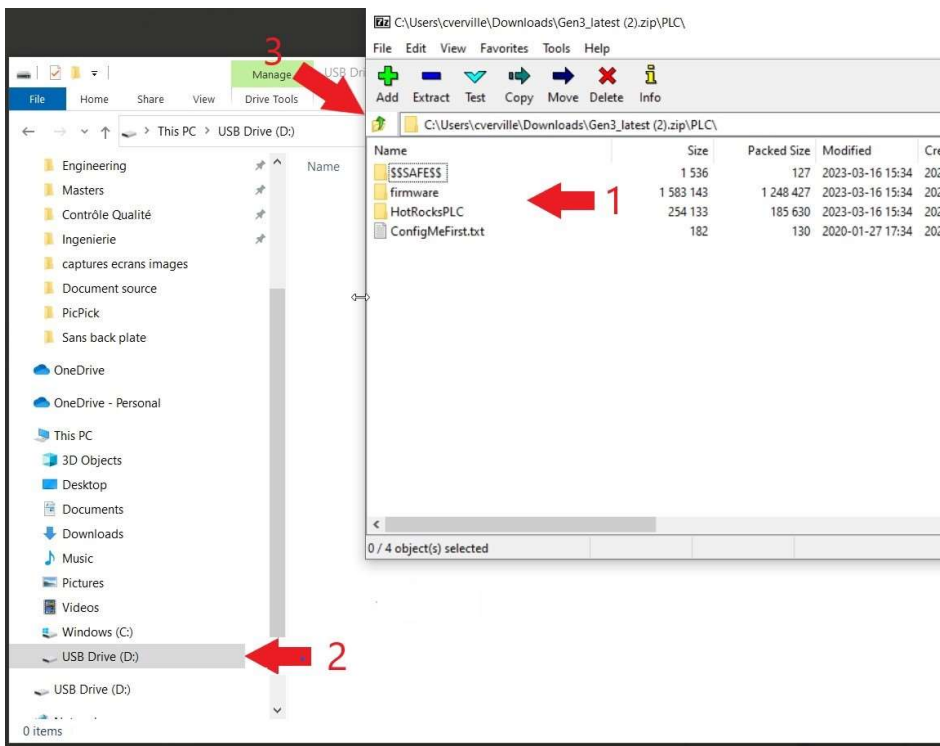

1- Click on the PLC directory. Click on the first file, press and hold the SHIFT key on the keyboard and select the last file. All 4 files should be blue. Release the SHIFT key.

2- With the mouse, go to the files to be copied. Holding down the left mouse button, drag the files to the file explorer window over USB Drive, and release the mouse button to start the transfer.

3- Click on this icon to perform the same procedure to copy the file contained in the HMI directory to the USB key.

- MicroSD card must contain 2 folders and 2 files;
  - **Firmware** (folder)
  - **HotRocksPLC** (folder)
  - **ConfigMeFirst.txt**
  - **\$\$SAFE\$\$** (hidden folder) not necessary
- The USB key contain only this file
  - **HotRocksHMI.cha**
- Be sure, there are no other files on the key or card.

### 3.2 Insert USB key and MicroSD card in the oven

- Power down the oven by turning off the main switch
- Close the main gas valve on the client gas pipe generally located on the wall.
- Remove oven back panels by unscrew the 6 Philips screw of the right panel by looking the oven from the back



- Put the Micro SD Card into the PLC. Insert the micro SD card in the side slot as shown below notch upside.

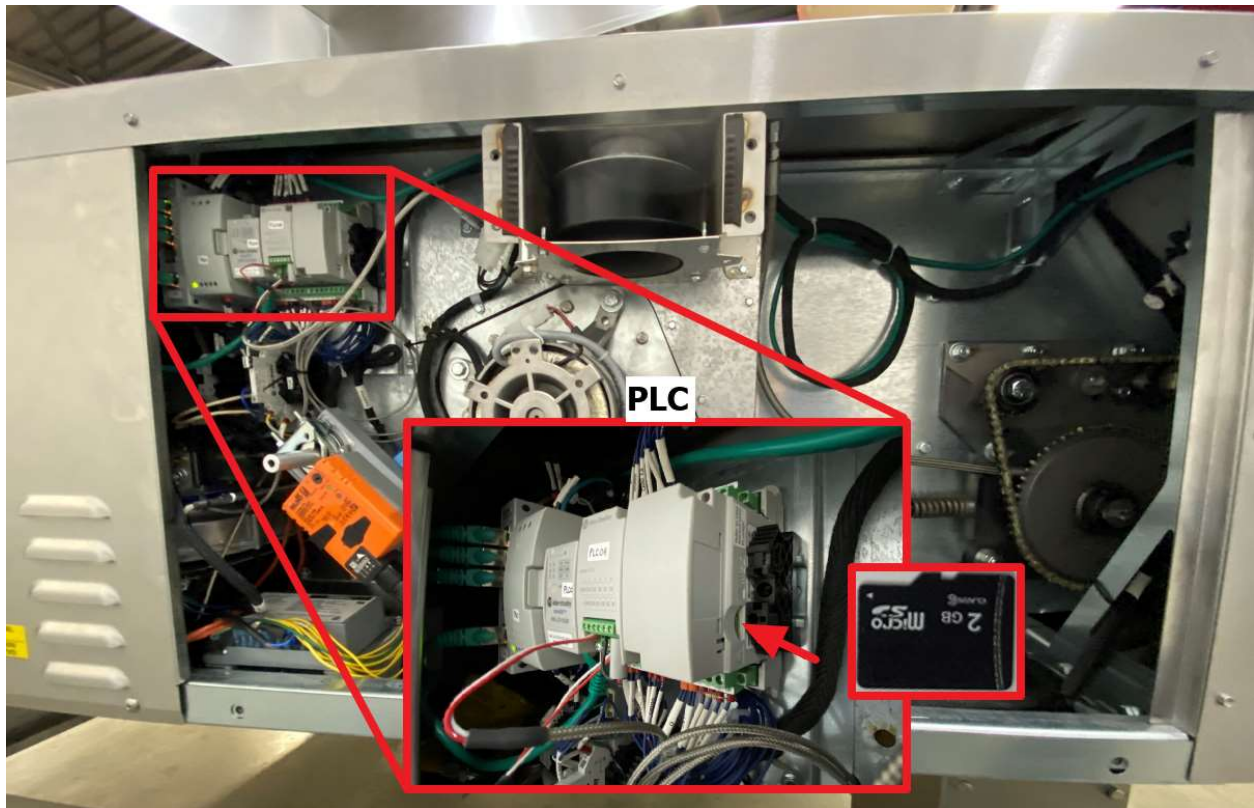

- Put the USB Key into the back of the HMI

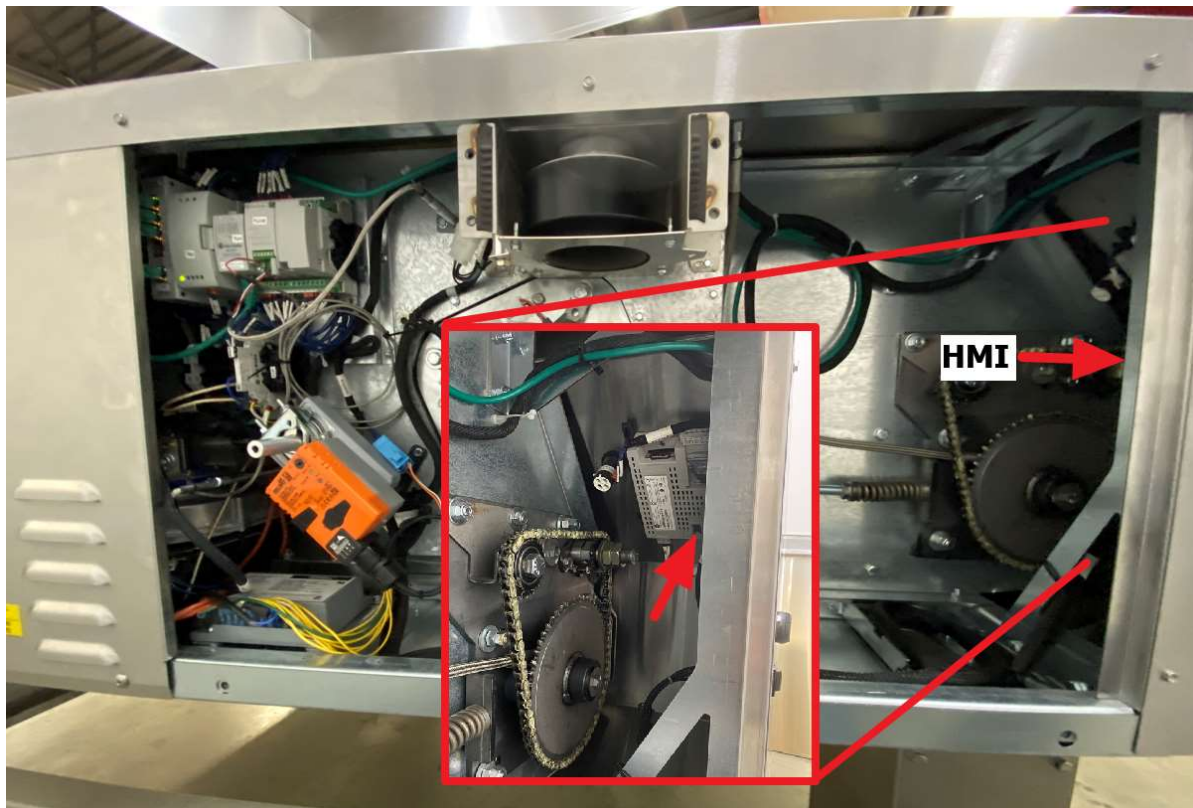

## 4 Perform the update

- Turn on the oven main switch
- Wait until the screen shows the home page, main screen.

### 4.1 PLC update

The PLC will update automatically if an SD card is inserted. It will read it and perform the update during the start-up screen process. You have nothing to do.

HMI screen update

To update the HMI screen, you have to go in the factory screen parameter. To do it follow the instruction below;

First, login technician mode. Follow the same steps previously shown at section 2. (Log oven's current settings) step "Login technician mode" then go back on the main screen.

- Go in "Configuration" page and then select "HMI screen parameters"

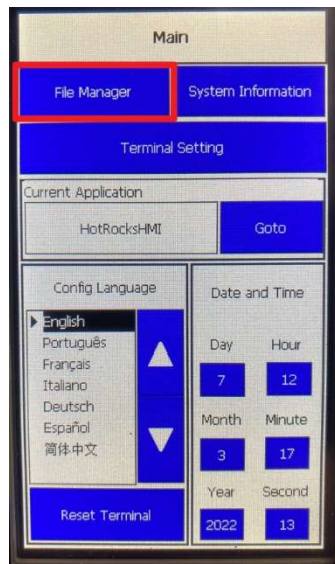
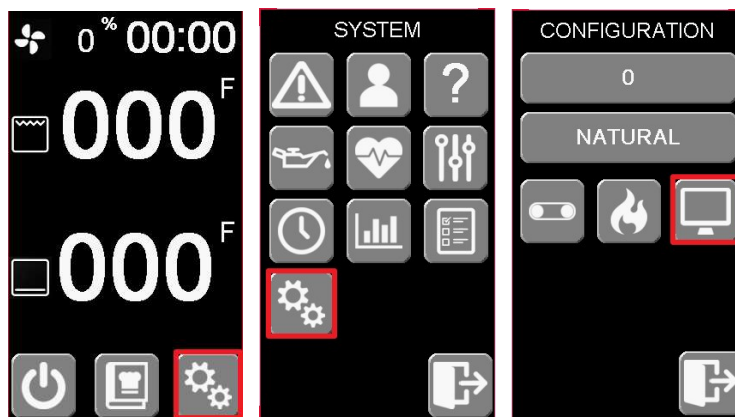

You will now enter in the Factory HMI screen parameters

- Once loaded click on « File Manager »



- Select;
  - SOURCE: **INTERNAL**
  - TO: **INTERNAL**

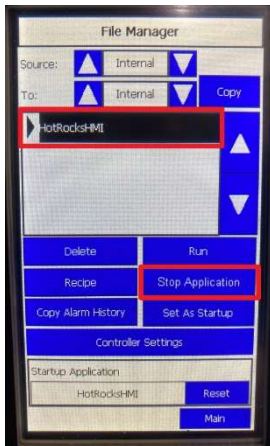

- Select the program and “Stop application”.
- After select “Delete application”.



- Select;
  - SOURCE: **USB**
  - TO: **INTERNAL**

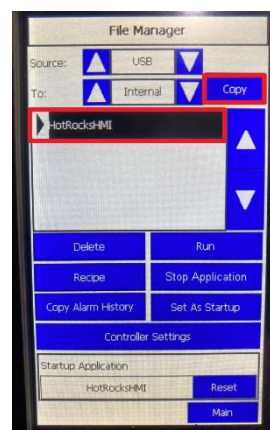

- Select program and click on “COPY”



- Select;
  - SOURCE: INTERNAL
  - TO: INTERNAL

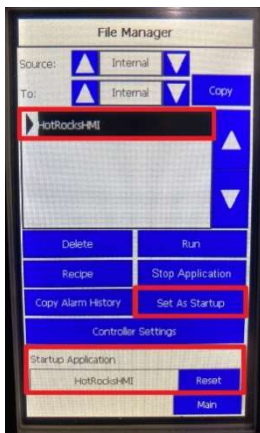

- Select program and click on "SET AS STARTUP". Be sure that the program now appears below in the "Startup Application" box.

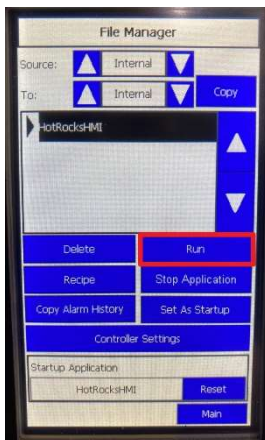

- At the end select "Run"

## 5 Oven reconfiguration

### 5.1 Remove the USB key and SD Card

- Turn off the oven switch
- Remove USB key and MICRO SD card.

### 5.2 Verify if the PLC and HMI version has been updated

- Turn on the oven and go in the “INFO / ABOUT” page to verify that is the latest version number shown. HMI and PLC version must be the same.

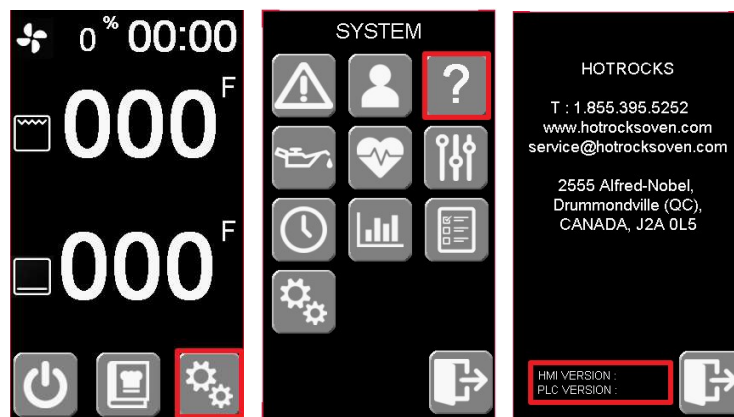

### 5.3 Re-configure the oven

- Power on the oven
- Wait until the screen shows the home page.



**WARNING: REFER TO SECTION 2 (Log oven's current settings) TO RE-CONFIGURE THE OVEN. BE SURE ALL NOTED PARAMETERS ARE THE SAME THEN BEFORE.**

You have to login User Technician mode to setup all parameters.

- To configure recipes:
  - On the main screen, adjust the temperature, cooking time and convection fan to desired set point.
  - Go to “RECIPES” menu
  - Select and hold the recipe box for 5 seconds to record settings.



**WARNING: BE SURE TO REINSTALL THE REAR PANEL AND REOPEN THE GAS VALVE BEFORE QUIT**

**CONGRATULATIONS YOU ARE DONE! YOUR OVEN IS NOW UP TO DATE AND READY TO ROCK!**



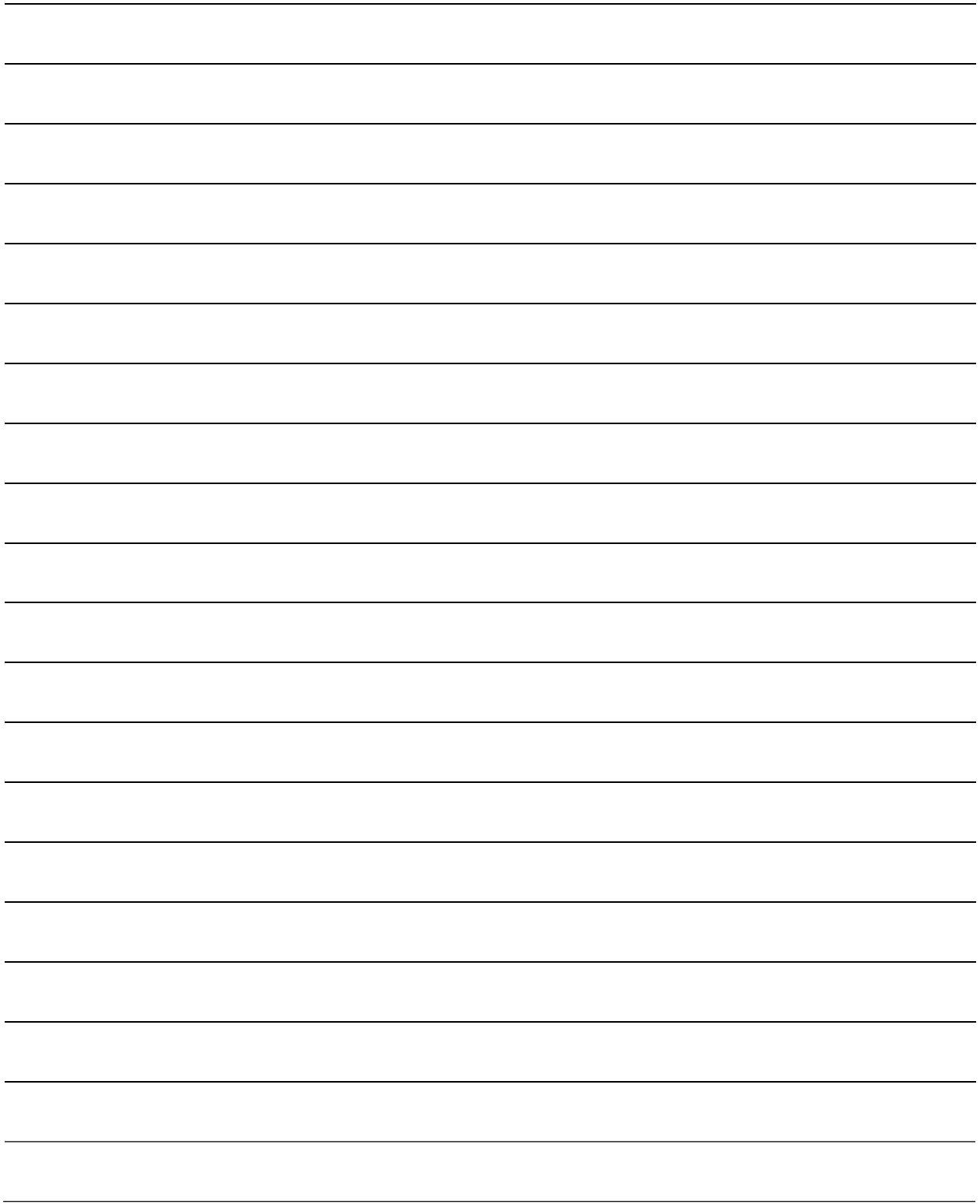

2555, Alfred Nobel, Drummondville  
(Québec) Canada J2A 0L5

T : 819 395-5151 / 855 395-5252

F : 819 395-5343

[hotrocksoven.com](http://hotrocksoven.com)

Follow-us

