

# ENTRY MESH CONVEYOR HEIGHT ADJUSTMENT

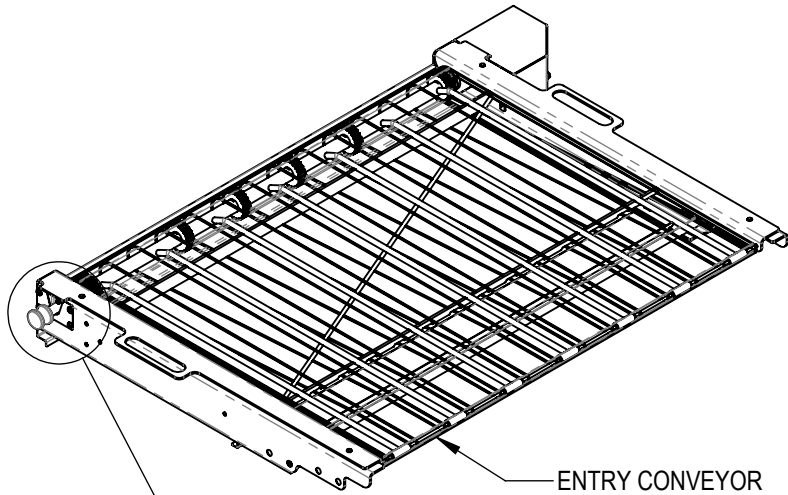

ENTRY CONVEYOR

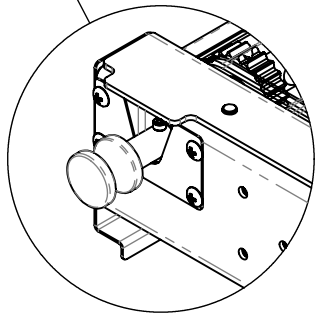

STEP 1 : PULL AND TURN THE KNOB TO UNLOCK THE MESH CONVEYOR

STEP 2 : REMOVE THE MESH CONVEYOR

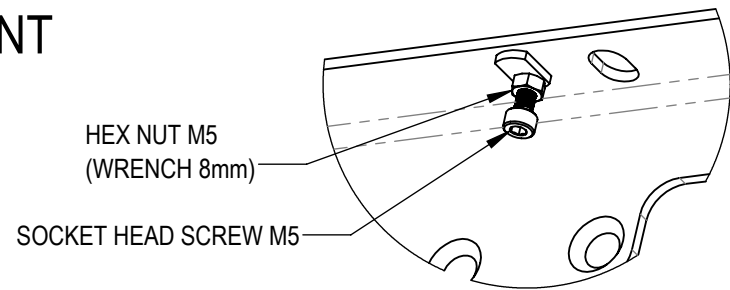

HEX NUT M5  
(WRENCH 8mm)

SOCKET HEAD SCREW M5

STEP 3 : UNSCREW THE NUT (KEY 8mm)

STEP 4 : SCREW THE SOCKET HEAD SCREW OUT OF THE ARMS OF THE MESH CONVEYOR SAME ON EACH ARMS.

STEP 5 : TIGHTEN THE NUT

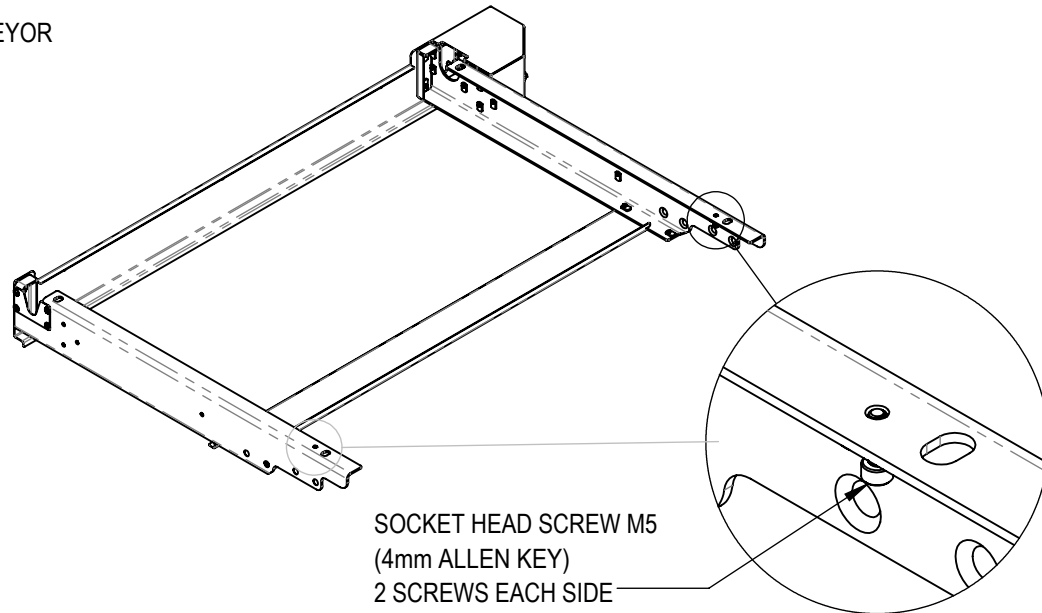

SOCKET HEAD SCREW M5  
(4mm ALLEN KEY)  
2 SCREWS EACH SIDE

STEP 6 : REINSTALL THE MESH CONVEYOR AND CHECK IF THERE IS ENOUGH CLEARANCE.

STEP 7 : PULL AND TURN THE KNOB TO RE-ENGAGE THE MESH CONVEYOR.

**KOROK**

REV.	MODIFICATION	DATE	INIT.
REVISIONS			