

Main Conveyor Lubrication

Make sure the oven is cold before starting this procedure.

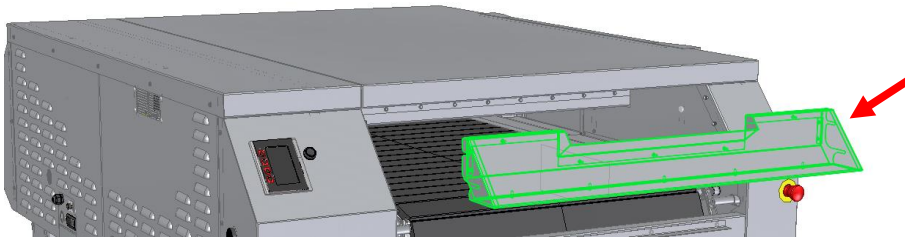

Remove the end cover.

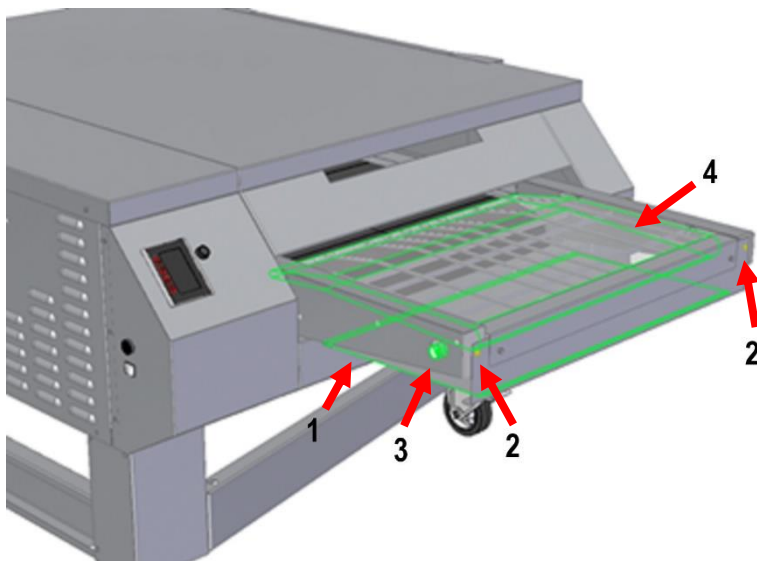

For a better access to the chaine, remove the convoyor.

- 1- Remove the crumb tray.
- 2- Remove the finishing plate by removing the 2 screw.
- 3- Be sure the mesh is cold. Place your hand on the mesh to move it forward and backward by pulling the handle to remove the wire belt.
- 4- Pull the wire belt up.

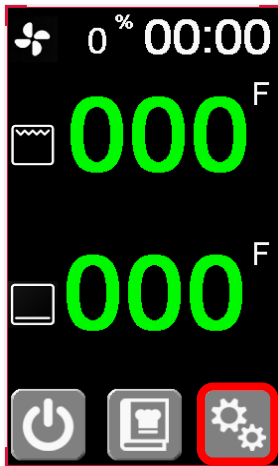

On the HMI, go to the lubrication setup page.

Press the system button on the bottom left corner of the main screen.



Basic screen

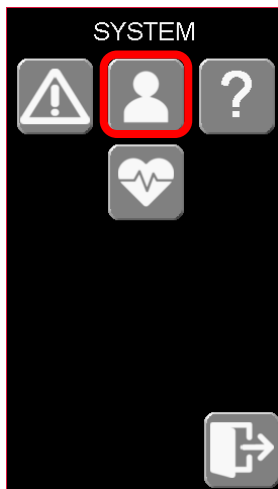

If you have the BASIC display, you must log in to access the lubrication mode.

If you have the lubrication icon , go to the next step.

In system menu, press  to enter the USER menu.

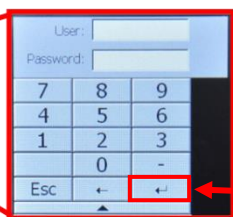
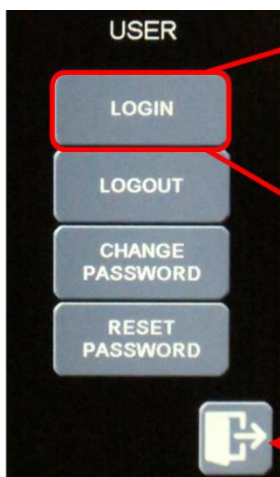

Press the LOGIN button and you login using the following credentials:

User: 2
Password: 911
Enter

If you get an error message, there was a mistake in the credential.

Press the exit button .

Exit

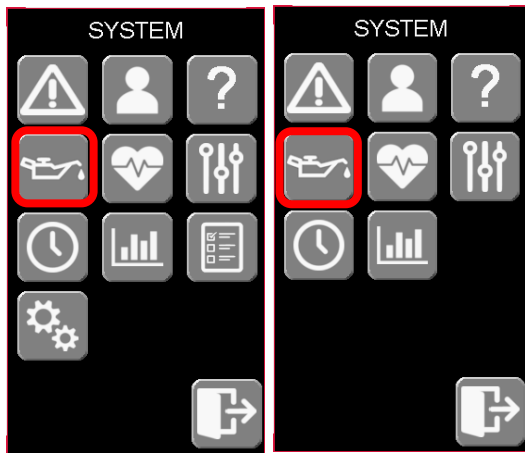

In the system menu, press the LUBRICATION icon

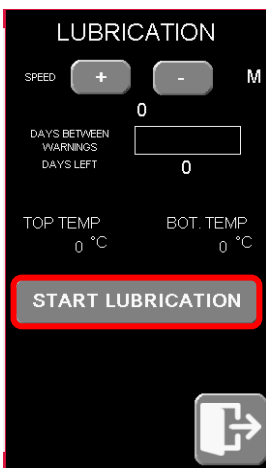

The oven will adjust itself to the proper settings for the lubrication.

Press **START LUBRICATION** to start the lubrication process.

You can set the conveyor speed to a different value by pressing **+** or **-**

On average, wait about 10 minutes for the oven reach the lubrication settings.

Locate the lubricant (FO75-0050) and shake well for 2 minutes. This lubricant is food grade quality and has been designed specifically for application on these ovens. No other lubricant will provide the correct coverage.

Note: that using a different lubricant type will void the warranty on these parts.



Apply the approved lubricant to each link of the chain as shown by a yellow strip in the illustration below. This needs to be done on both sides of the chain. There is 6 months worth of lubricant one container.

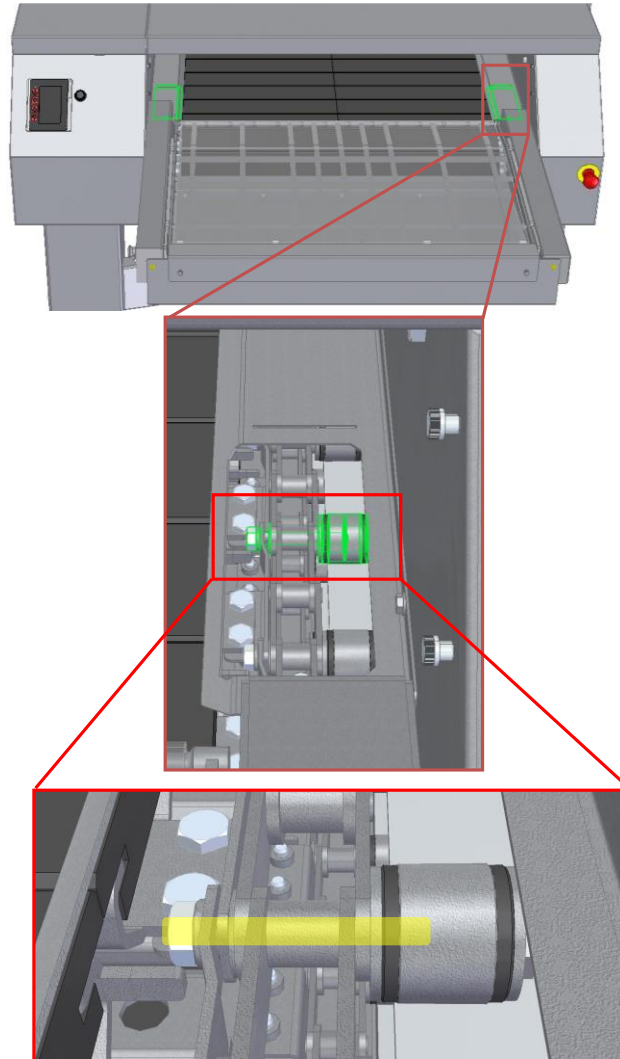

After applying lubricate on both chains, leave the oven running for 30 minutes allowing the lubricant evaporate.

Press the button **LUBRICATION MOD** to stop the conveyor and shutdown the burner.

Reassemble the removed parts, and put the oven back into normal usage. Depending the amount of lubricant applied, any excess may still continue to evaporate. The evaporation will produce an odourful non-toxic fume.