



HOT ROCKS

Hot Rocks Oven – Installation device user manual guide

FOR SUPPORT
service@hotrocksoven.com

1 800 668-1883

TABLE OF CONTENTS

1 Material and tool needed	5
2 Tool device and dolly assembly	7
2.1 Installation device assembly.....	7
2.2 Wheel buggy assembly	8
3 Tool inspection.....	9
4 Oven parts removal and uncrating	10
5 Lifting plate assembly on oven.....	12
6 Tool positioning on oven.....	14
7 Lifting rotating and manipulation	15
7.1 Dolly utilisation	16
8 Installation device removal and disassembly.....	17

This document purpose is to guide the user to use properly and safely the Hot Rocks installation device for handling (lifting, rotating and moving).



WARNING: Before using this equipment be sure to have read this document properly and be qualified and properly trained.



WARNING: Do not use this device for other purpose than specified. This device is designed for **Hot Rocks ovens GEN2. 3. 4 (VOLCANO)** only (HR7022, HR7033, HR9333, VOL4033) **one stage**



WARNING: In any case, operator must **never** stand under or next to lifted load. Always keep your distance.



WARNING: Always wear proper safety protection equipment to use this device. Wear safety glasses, gloves, and steel toe boots.



Avoid these recommendations can lead to serious injury and death.



Safety, inspection, maintenance is the user responsibility.

1 Material and tools needed

Installation device parts:

- Vertical column beam and mobile winch carrier assembly
- Column base
 - HR7022 kit
 - HR7033 kit
 - HR9333 kit
- Horizontal longitudinal transverse beam
- Locking hitch pins

Parts for GEN2 GEN3



Adaptor supplementary parts for GEN 4 Volcano

PHOTOS

Wheeled dolly parts:

- Caster wheels ends
- Adjustable transverse longitudinal junction beam
- Locking hitch pins

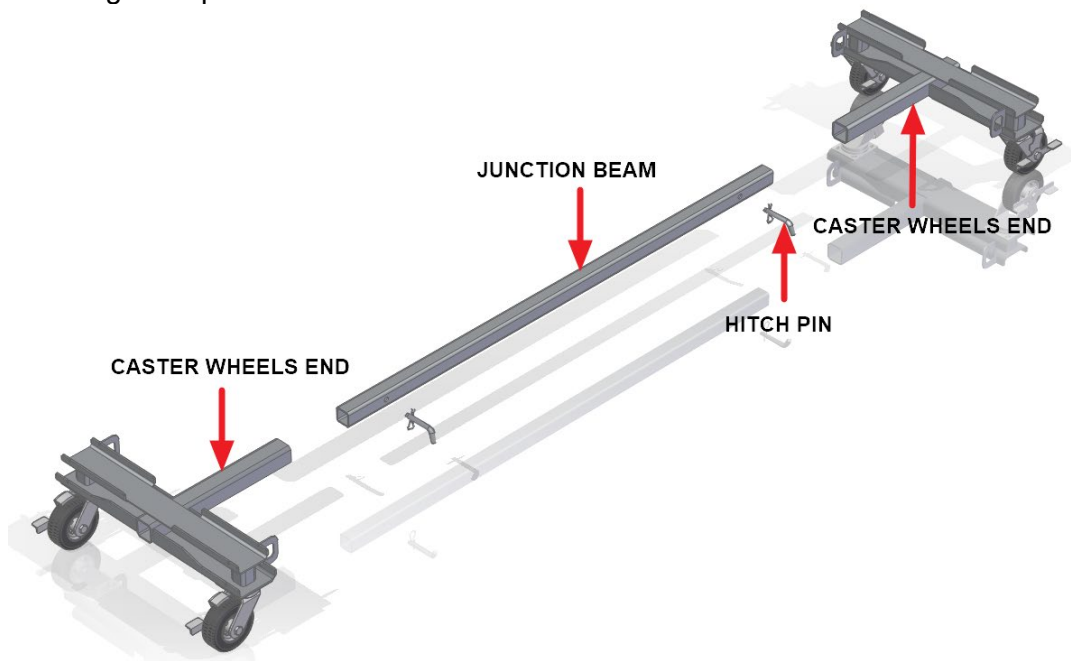

Tools:

- Ratcheting tie-down straps
- Drill or impact drill
- Robertson #2 drill bit
- Hex box drive 5/16"



2 Tool device and dolly assembly

2.1 Installation device assembly

- Be sure the mobile winch carrier is stuck at lifted-up position to avoid it moving during assembly.

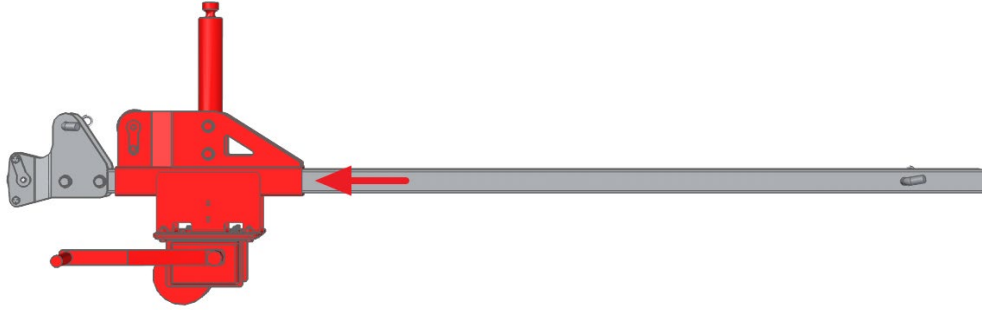

- For heavy device parts use the dolly to move them.
- Assemble the base on the vertical column on the floor and secure it with hitch pin.

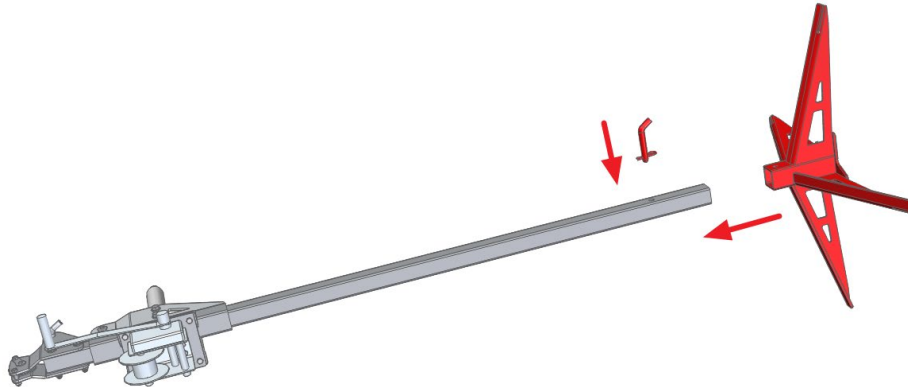

- Raise the assembly to vertical position.

2.2 Wheel buggy assembly

- Assemble the horizontal transverse beam on the wheel ends and secure with hitch pins. Use the closest holes set for HR7033 / HR7022 and furthest holes set for HR9333 models.

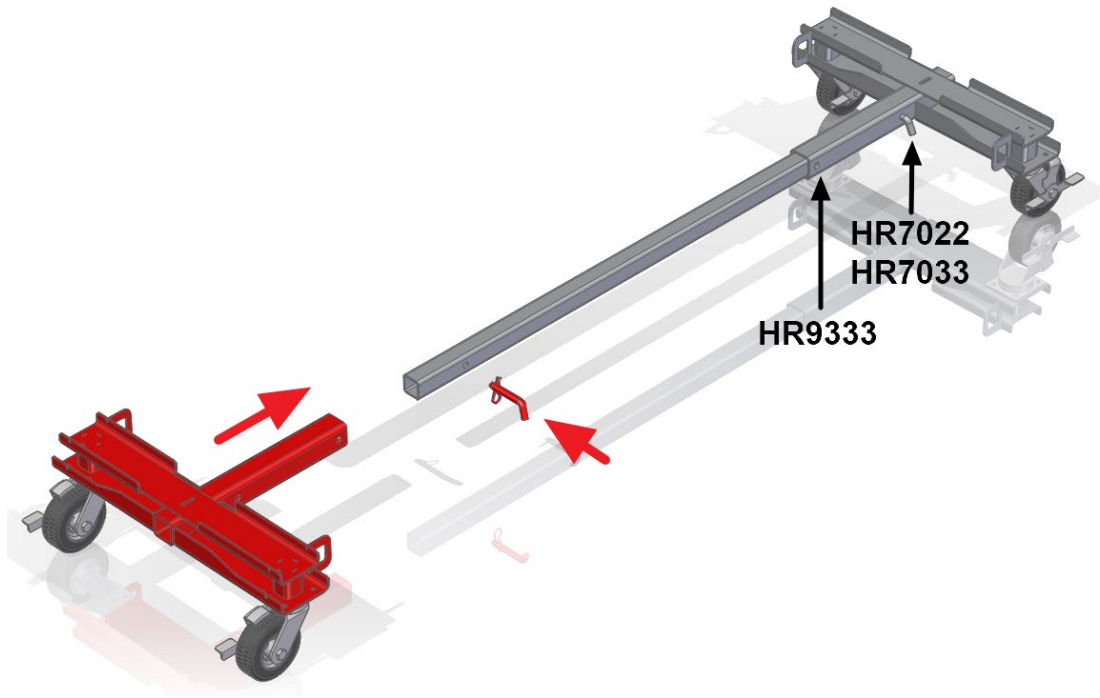

*****For Hot Rocks GEN 4 Volcano caster wheels end must be inverted as shown below**

PHOTO

3 Tool inspection



WARNING: The proper use and inspection is the user responsibility, don't use this device if a component is worn, broken, or not maintained.



WARNING: Proceed to device inspection following this procedure before each use.

Inspection check list:

- ✓ Inspect all components to be sure they are clear of dents or puncture which can lead to equipment failure.
- ✓ Unroll the winch cable and be sure it is not bend and there is no broken strand.
- ✓ Ensure the vertical beam is lubricated with general purpose grease to avoid rust and provide low friction surface.
- ✓ Ensure the component are free of dirt, debris, and metal chips to avoid jam.
- ✓ Ensure the pulleys/sheaves are free to rotate easily.
- ✓ Ensure the winch rotate freely and there is no damage to the drum and gear.
- ✓ Verify each bolt are properly tighten, no loose bolts or nuts.
- ✓ Verify each hitch pins are properly secure with hairpin.
- ✓ Verify the plates aren't bend, corroded or damaged.

4 Oven parts removal and uncrating



WARNING: The oven must be free of cooking surface. Stone or steel slabs must be removed.

- Remove the wood cross braces and cardboard from the oven. Keep the wood pallet underneath.

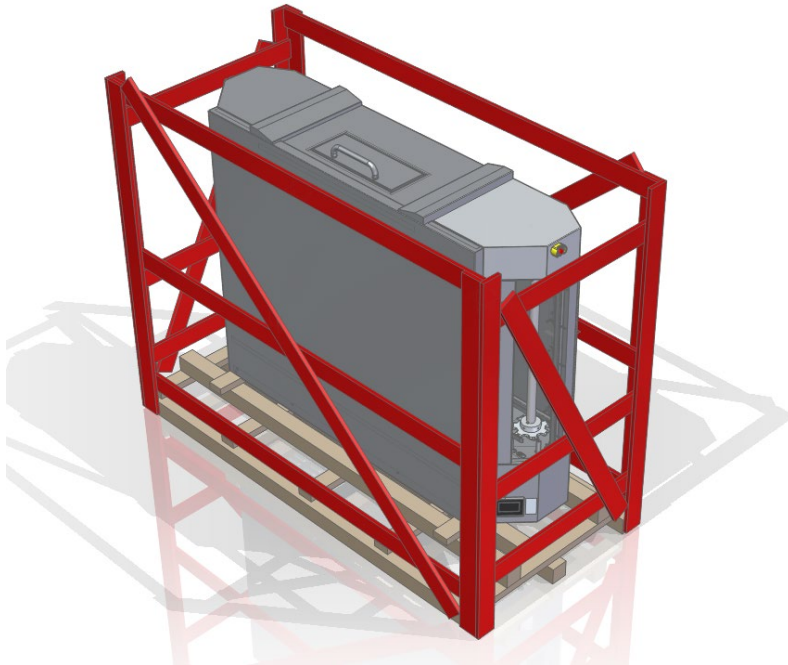
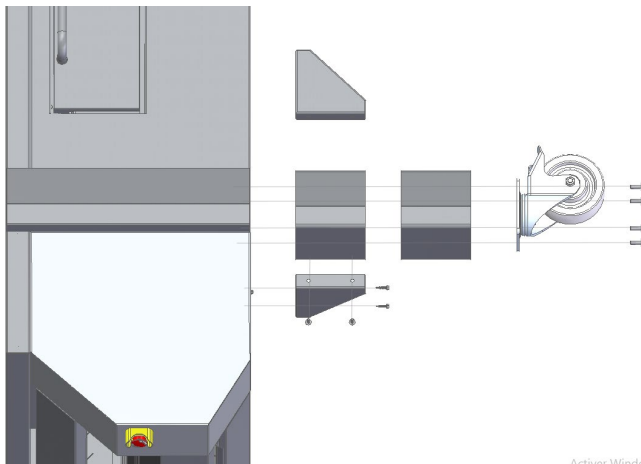

PHOTO BOITE

- Install the legs with the caster wheels ***SEE installation guide for more details***



Activar Windows

PHOTO VOLCANO

- Remove the wood screws fixing the 2 cross members which the oven is sit on.

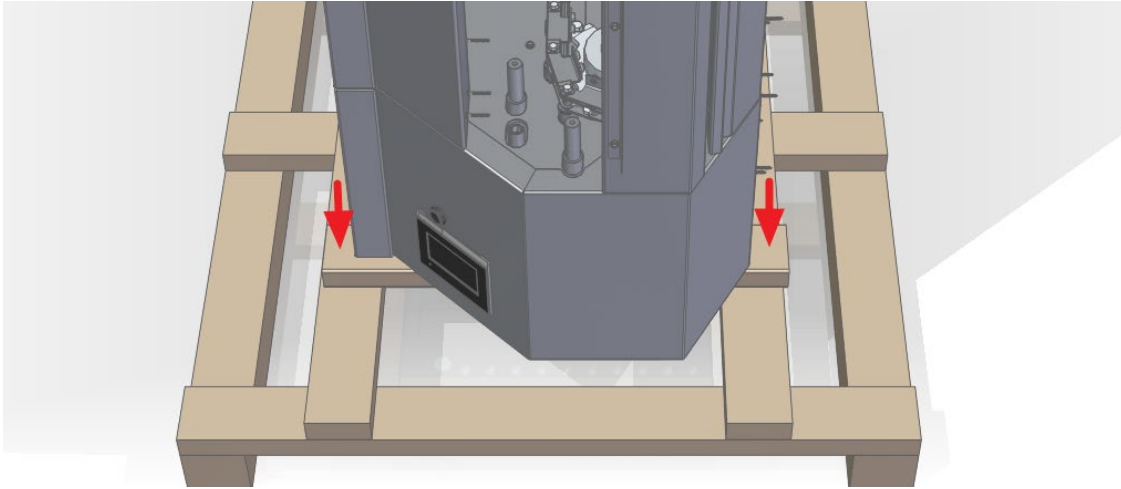

- Remove crumb trays and external finish insulation panels each side. See below shown in red.

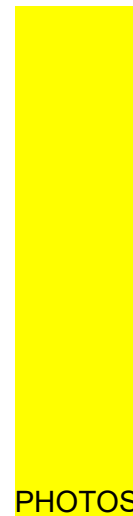
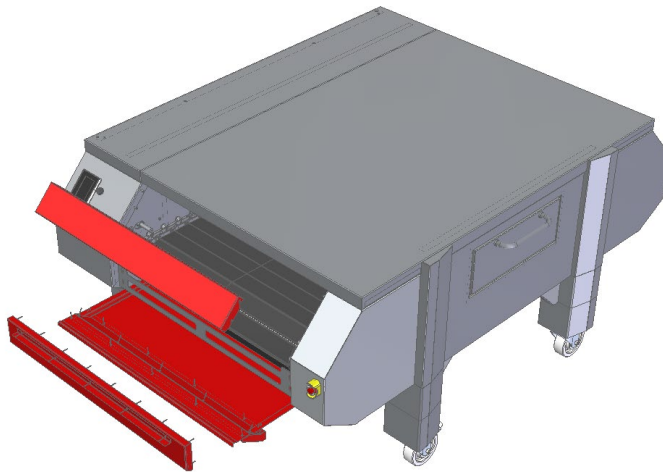

PHOTOS

*** Entry and exit conveyor must not be installed at this point ***

5 Lifting plate assembly on oven

Install the proper internal fixation plate in the oven. Be sure to use the right plate matching the model of the oven. The plate model is written / engraved on. Place the plate as per indication DOOR SIDE / REAR SIDE. See example below:

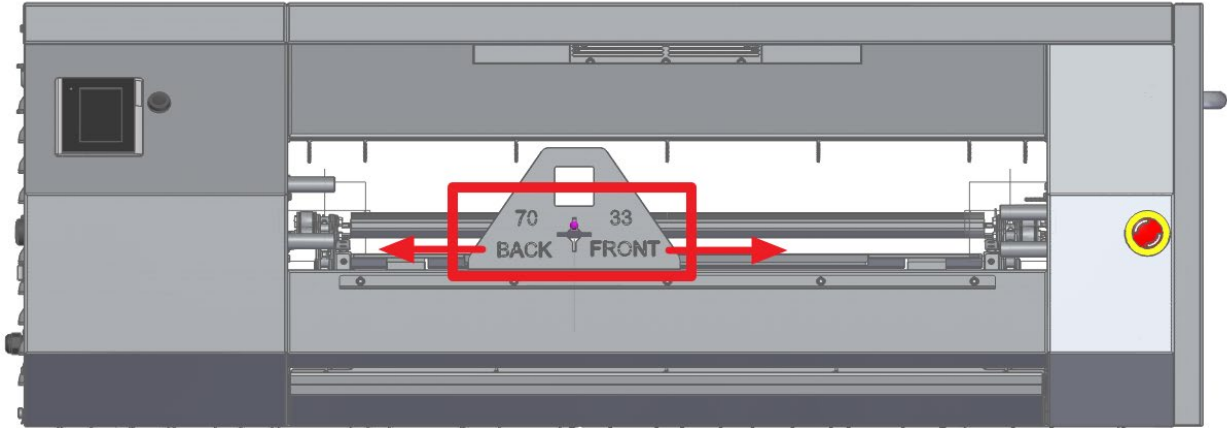

VOLCANO PIC FRONT

- These plates must be installed by the inside of the oven behind the principal conveyor shaft as shown below:

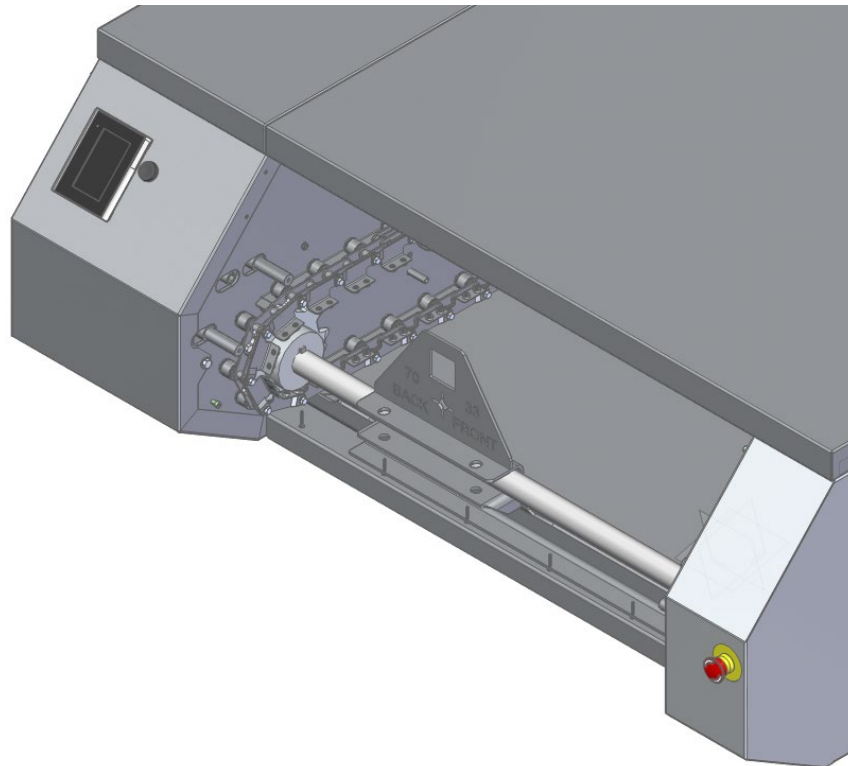

- Slide the plates in place behind the shaft and secure them in place with hitch pins.
- If there is a chain reinforcement part preventing the positioning of the plate, simply unscrew it and screw it further away.
- When the internal plates are in place and secure, pass the transverse longitudinal horizontal beam through the internal plates square holes. Be sure the round holes in the tube are oriented to be able to match the tube adaptor assembly with the cross cut-out.

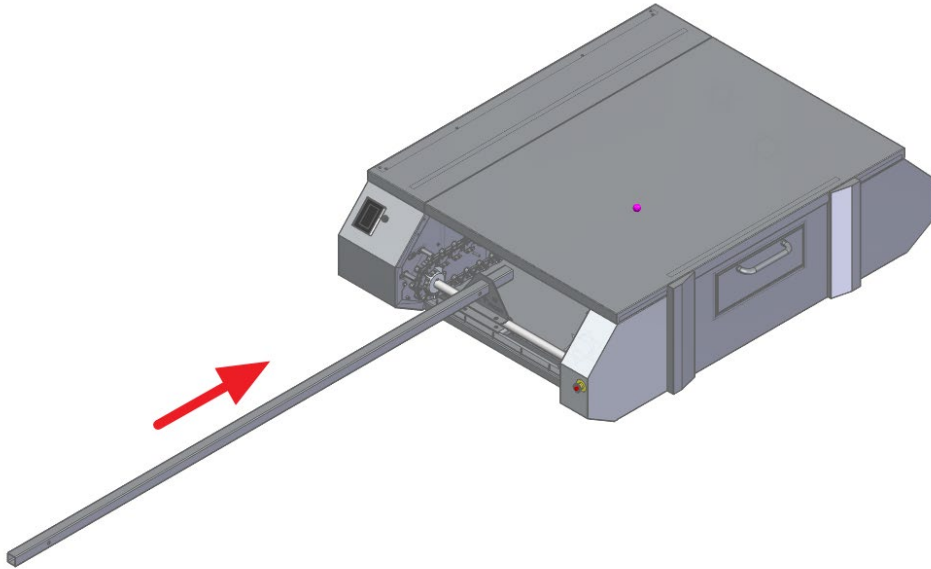

- Install the two ends adaptor parts on the transverse beam. *****VERY IMPORTANT Be sure to align both female cross cut-out and male cross plates parts.** Secure in place with hitch pins.

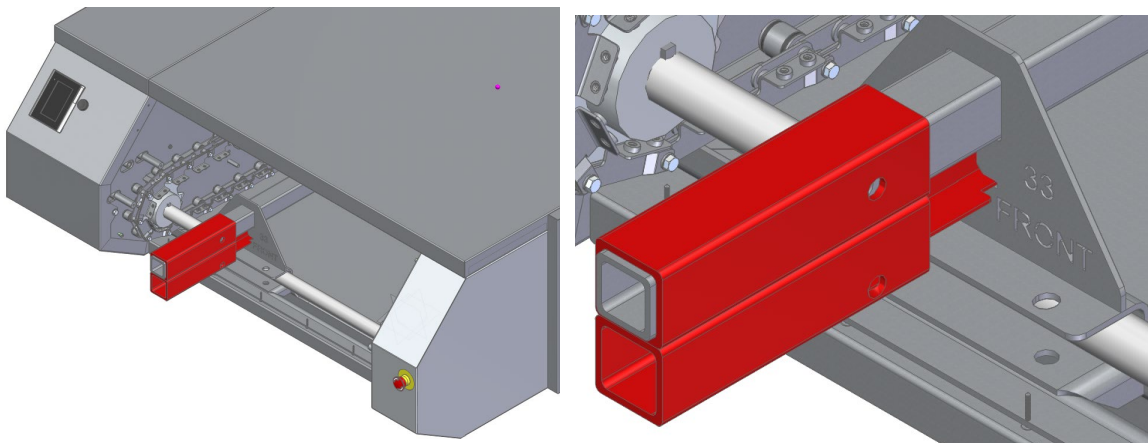

6 Tool positioning on oven



WARNING: Only use the installation device on a leveled flat surface to ensure a proper tool stability.

- Bring the winch column assembly each side of the oven.
- Adjust the height of the mobile winch carrier to be able to insert the round shaft post in the square tube adaptor part with the cross end.
- Secure the shaft with a hitch pin.

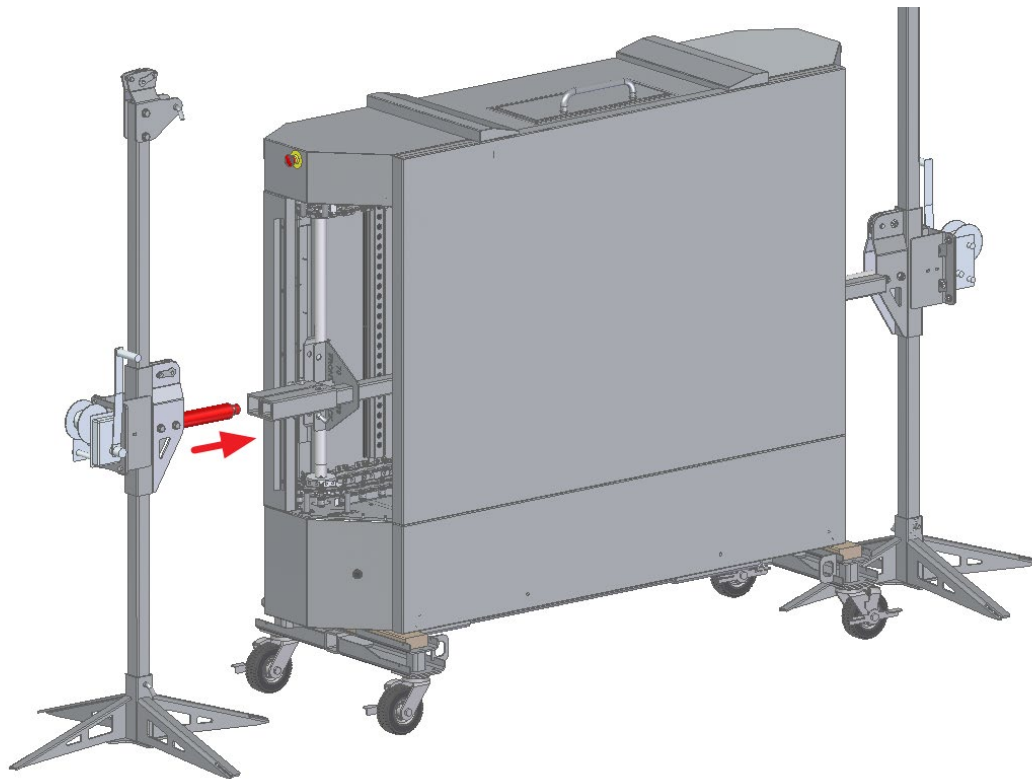

7 Lifting rotating and manipulation



WARNING: Always lift both sides evenly. The oven must always be leveled, maximum 2" difference height from each end.

- Once everything in place, gently rotate the winch handle to lift the oven. Lift both side at the time synchronously. Never have more than 2 inches maximum difference height between both sides.

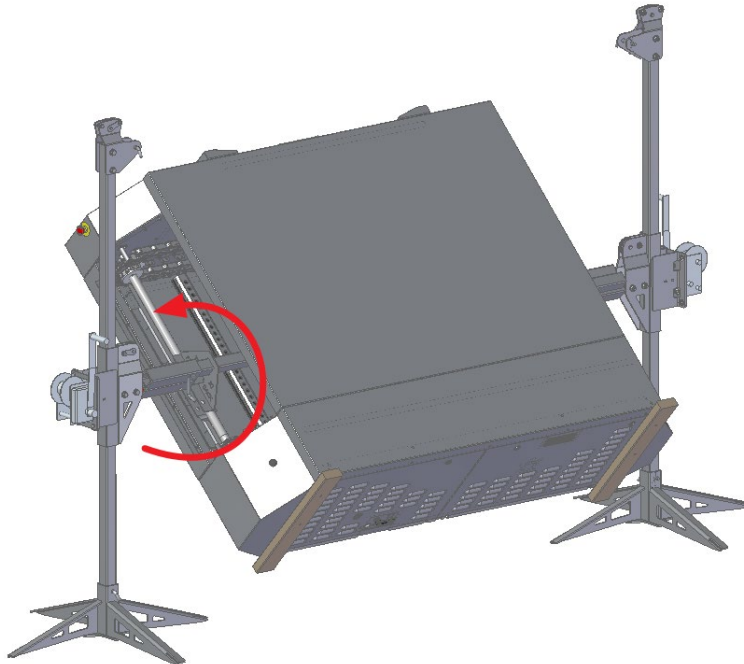
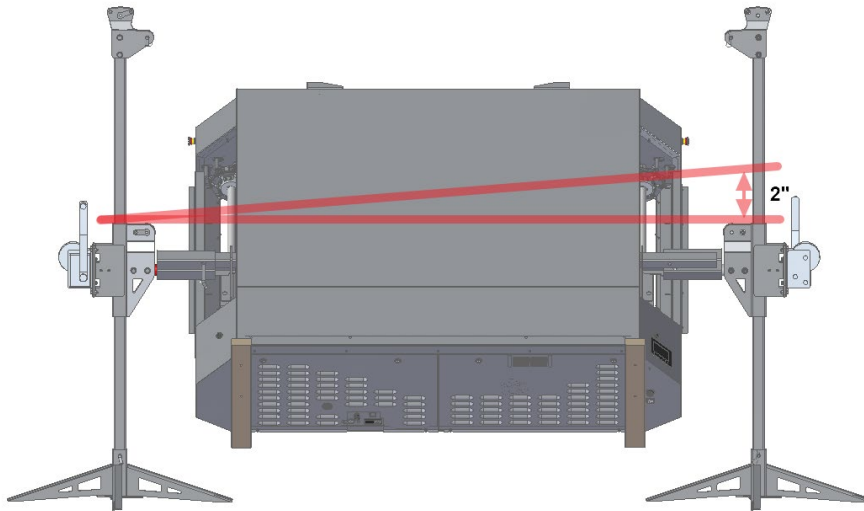

- Be sure the oven is balanced during lifting.
- Stand behind the lifting column, keep your distance from the oven when the load is lifted.
- When the oven is off the ground you can redeposit on the rolling buggy or rotate it to sit on the floor or roll another oven underneath to stack. Rotate the oven by hand, be sure to never stand under load.
- When positioned, simply crank the winch counter clockwise to bring the oven down.

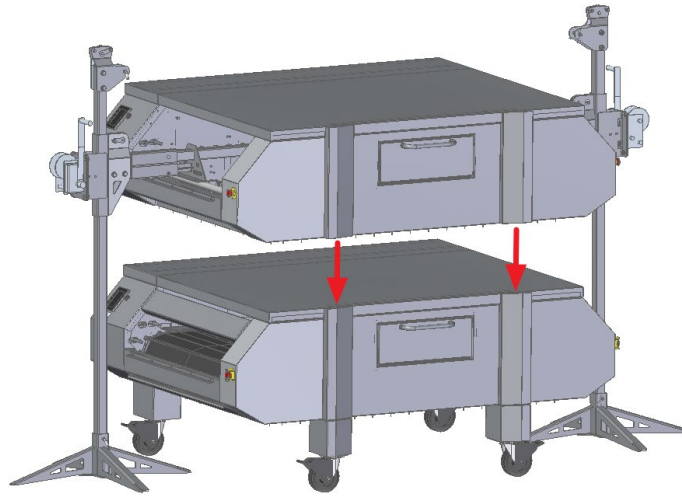

7.1 Dolly utilisation

- ***** If the oven is on the side seated on the dolly, be sure to secure it with ratcheting tie-down straps before moving it. Do not overtight to avoid oven panels distortion or damaged.*****

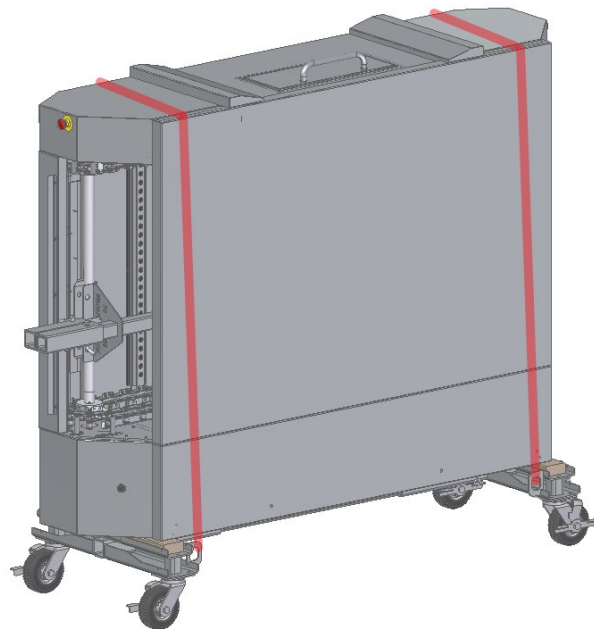

8 Installation device removal and disassembly

After the manipulation are done and the oven is secure in place you can remove the installation device parts. Simple undone the previous steps in reverse.

Unmount the internal oven parts and the winch carrier column bases.

For storage, ensure the parts are dry and lubricated to avoid corrosion.

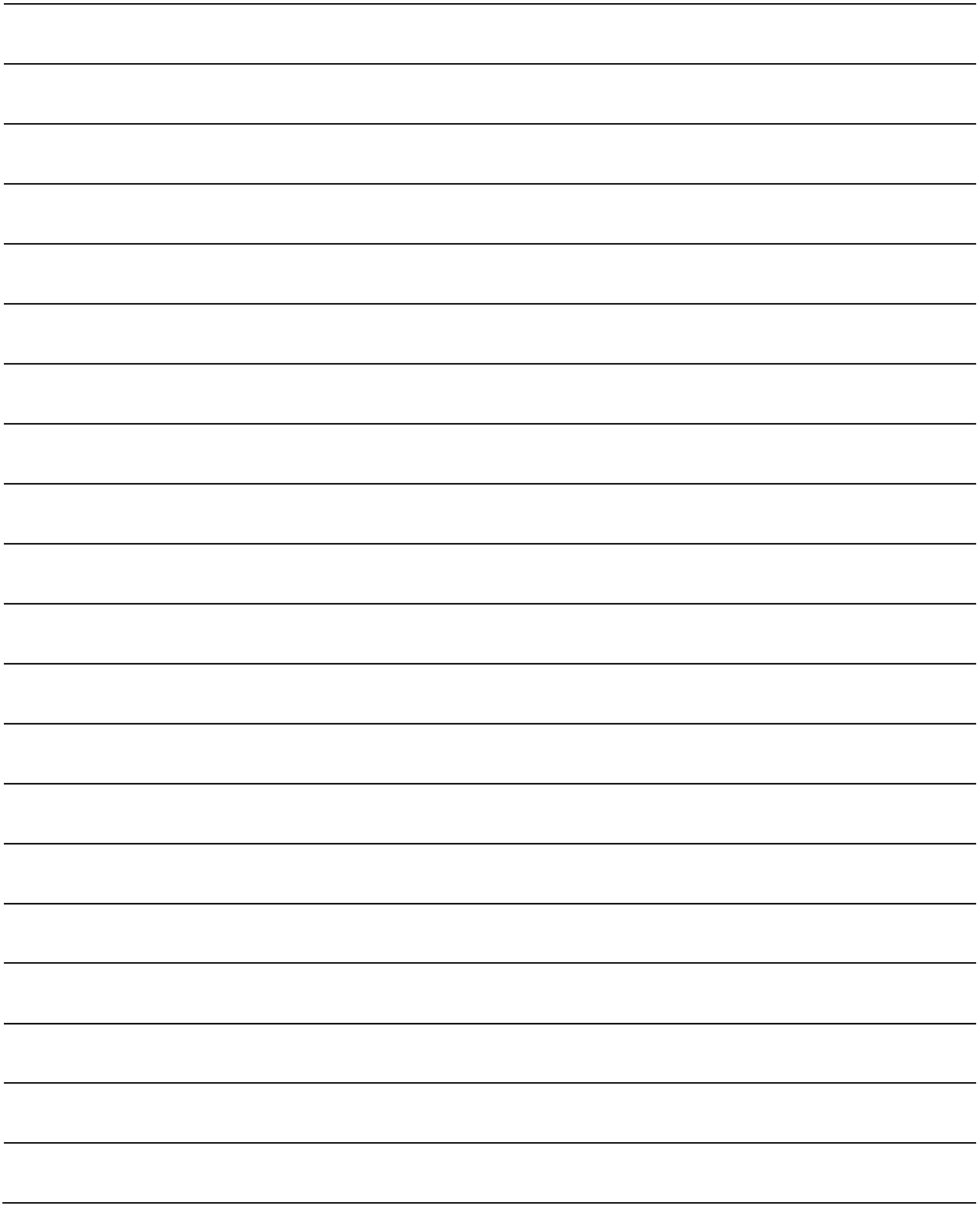

2555, Alfred Nobel, Drummondville
(Québec) Canada J2A 0L5

T : 819 395-5151 / 855 395-5252

F : 819 395-5343

hotrocksoven.com

Follow-us

